



Installation Guide

for Adhered Concrete Masonry Veneer
3rd edition





Table of Contents

Definitions/Abbreviations.....3
 References.....3
 Summary Table.....4
 Workmanship.....6
 Material Requirements6
 Surface Preparation.....7
 Adhered Concrete Masonry Veneer Installation9

Drawings / Cross Sections

Fig. 1. Wall Assembly..... 11
 Fig. 2. Wall Section, Typical..... 12
 Fig. 3. Foundation Wall Base 13
 Fig. 4. Foundation Wall Base – ACMV Overlapping Foundation..... 14
 Fig. 5. Foundation Wall Base – ACMV Continuing Down Foundation..... 15
 Fig. 6. Cladding Transition..... 16
 Fig. 7. Outside Corner 17
 Fig. 8. Inside Corner 18
 Fig. 9. Horizontal Transition..... 19
 Fig. 10. Vertical Transition..... 20
 Fig. 11 & 12. Eave21-22
 Fig. 13 & 14. Rake.....23-24
 Fig. 15 & 16. Side Wall-Comp. Shingles.....25-26
 Fig. 17 & 18. Side Wall-Tile Roof27-28
 Fig. 19, 20, & 21. Window Sill, Jamb, Head29-30-31
 Fig. 22. Kickout Flashing (Wall-Eave-Roof Intersection)..... 32
 Fig. 23. Cricket (Roof Penetration)..... 33
 Fig. 24. Chimney Chase..... 34
 Fig. 25 & 26. Column Base.....35-36
 Fig. 27, 28 & 29. Penetrations (Flanged, Non-Flanged with Building Paper WRB, Non-Flanged with Housewrap WRB 37-38-39
 Fig. 30 & 31. Penetrations (Fixture, Dryer)40-41
 Fig. 32. Decks (Ledger Board) 42
 Fig. 33. Wall Cap..... 43
 Fig. 34. Wall Assembly – Optional Rainscreen – Drainage Medium..... 44
 Fig. 35. Wall Assembly – Optional Rainscreen – Strapped..... 45
 Fig. 36. Foundation Wall Base – Optional Rainscreen System..... 46
 Fig. 37. Wall Section – Optional Rainscreen System..... 47
 Fig. 38. Retaining Wall (CMU)..... 48

Disclaimer

This Guide addresses generally accepted methods and details for installation of Adhered Concrete Masonry Veneer. To the best of our knowledge, it is correct and up to date. However, the document is designed only as a guide; and it is not intended for any specific construction project. **The MVMA makes no express or implied warranty or guarantee of the techniques, construction methods or materials identified herein.**

It is understood that there are alternative means or methods that might be required and/or recommended based on project conditions, manufacturer’s recommendations, or product characteristics.

Details in this guide that address the Adhered Concrete Masonry Veneer and its interface with the building components are not intended as specific recommendations for the construction of the interfacing building components.

Reproduction of the material herein is not permitted without the express permission of the MVMA.

Masonry Veneer Manufacturers Association
 National Press Building
 529 14th Street, NW, Suite 750
 Washington, DC 20045
 202/591-2438 (phone)
 202/591-2445 (fax)
 www.masonryveneer.org

Masonry Veneer Manufacturers Association (MVMA) represents the adhered concrete masonry veneer industry’s manufacturing companies and their suppliers. The mission of the organization is to advance the growth of the manufactured masonry veneer products industry through proactive technical, advocacy, and awareness efforts.

This Guide for builders, architects, designers, masons, installers and other construction professionals illustrates typical applications of Adhered Concrete Masonry Veneer.

It is the responsibility of all architectural and construction professionals to determine the applicability and appropriate application of any detail to any specific project.

Copyright © 2012 by the Masonry Veneer Manufacturers Association. All rights reserved.

Definitions

Adhered Concrete Masonry Veneer (ACMV) — lightweight, architectural, non load-bearing product that is manufactured by wet cast blending cementitious material, aggregate, iron oxide pigments, and admixtures to simulate the appearance of natural stone.

Note: The MVMA recognizes there are many names used to describe Adhered Concrete Masonry Veneer products. Manufactured Stone Veneer is used commonly throughout the industry and by some manufacturers. In the International Building Code, Adhered Concrete Masonry Veneer products are referred to as Adhered Masonry Veneer. In the ICC-ES Acceptance Criteria, AC51, the product is called Precast Stone Veneer. This guide will use ACMV (Adhered Concrete Masonry Veneer) when referencing the product.

CMU – Concrete masonry unit

Fasteners — Corrosion resistant hardware used to secure lath and flashing material to wall system.

Flashing — Material used to restrict the seepage of moisture around any intersection or projection of materials in an assembly.

Lath — Corrosion resistant mesh building material fastened to the substrate to act as base for adhering plaster or mortar.

Mortar — A workable paste mixture of cementitious material, water, and aggregate used to bond masonry construction materials together and fill spaces between.

Mortar Grout — Mortar mixture used to fill joints and cavities in masonry construction.

Mortar Scratch Coat — Base coat of mortar used in installation. Cross raked to improve bond of subsequent mortar layers.

Mortar Screen — Sheet material designed to prevent the mortar scratch coat from filling the drainage space.

Mortar Setting Bed — Mortar used to adhere the ACMV to the substrate or scratch coat.

Sealer — Liquid material used over ACMV to protect against staining and moisture penetration.

Wall System — The constructed exterior or interior vertical framework and substrate of the building.

Water Resistive Barrier — Material used to restrict the transmission of moisture to the surface behind.

Abbreviations

ACMV — Adhered Concrete Masonry Veneer

Blk'g — Blocking

Lbs. — Pounds

Mfr's — Manufacturer's

Min. — Minimum

OSHA — Occupational Safety and Health Administration

psi — Pounds per square inch

P.T. — Pressure treated (wood preservative)

Req'd — Required

SAF — Self Adhering Flashing

WRB — Water Resistive Barrier

References

ANSI Accredited Evaluation Service — An ANSI accredited third-party organization that issues an evaluation report affirming a specific building product meets building code requirements.

International Code Council — Evaluation Service (ICC-ES) — An organization that performs technical evaluations on building products, components, and construction methods for building code compliance. In the case where the building code is silent or ambiguous as to a product's requirements or a specific construction method, ICC-ES may develop "Acceptance Criteria" (AC) for the product or construction method. www.icc-es.org

International Building Code (IBC) — Building code that provides minimum requirements for safety, health, and welfare of life and property from hazards of the built environment. The provisions of this code apply to the construction, alteration, addition, replacement, repair, use and occupancy of all buildings except one and two family dwellings, and multi single-family townhomes not more than three stories in height. www.iccsafe.org

International Residential Code (IRC) — Building code that provides minimum requirements for safety, health, and welfare of life and property from hazards of the built environment. The provisions of this code apply to the construction, alteration, addition, replacement, repair, use and occupancy of detached one and two story dwellings and multi single-family townhomes not more than three stories in height. www.iccsafe.org

ANSI — American National Standards Institute, www.ansi.org

AC308 — ICC-ES Acceptance Criteria for Water Resistive Barriers.

AC51 — ICC-ES Acceptance Criteria for Pre-Cast Stone Veneer.

AC275 — ICC-ES Acceptance Criteria for Glass Fiber Lath used in Cementitious Exterior Wall Coating or Exterior Cement Plaster (Stucco)

ACI 530 — Building Code Requirements for Masonry Structures (ACI 530\ASCE 5\TMS 402). This standard is produced through the joint efforts of the American Concrete Institute (ACI), and the Structural Engineering Institute of the American Society of Civil Engineers (SEI/ASCE) through the Masonry Standards Joint Committee (MSJC) and The Masonry Society (TMS).

ASTM International — Previously American Society for Testing and Materials. ASTM is a developer of technical standards for products, systems, and services. www.astm.org

ASTM C144 — Standard Specification for Aggregate for Masonry Mortar

ASTM C270 — Standards Specification for Mortar for Unit Masonry

ASTM C482 — Standard Test Method for Bond Strength of Ceramic Tile to Portland Cement

ASTM C847 — Standard Specification for Metal Lath

ASTM C1032 — Standard Specification for Woven Wire Plaster Base

ASTM C1063 — Standard Specification for Installation of Lathing and Furring to Receive Interior and Exterior Portland Cement Based Plaster

ASTM C1325 — Standard Specification for Non-Asbestos Fiber-Mat Reinforced Cementitious Backer Units

ASTM D226 — Standard Specification for Asphalt Saturated Organic Felt Used in Roofing and Water Proofing

Summary Table

Wall System	Water Resistive Barrier	Lath	Fastening	Scratch Coat
<p>Wall Type: Wood or steel stud, no more than 16" O.C.</p> <p>Rigid Sheathing: Gypsum wall board Plywood OSB Concrete Board Fiber Board</p> <p>Note: Non-rigid insulation board over rigid sheathing is limited to max 1/2" thick.</p>	Minimum two separate layers WRB. See Water Resistive Barrier, Page 8.	2.5 lb. or 3.4 lb. self-furred corrosion-resistant lath (ASTM C 847) Or 18 gauge woven wire mesh (ASTM C 1032) Or Alternate lath acceptable with a product evaluation acceptance report showing compliance to ICC-ES AC 275.	Corrosion resistant fasteners (ASTM C 1063) minimum 3/4" nail penetration into wood framing member, or minimum 3/4" staple penetration into wood framing member, or minimum 3/8" penetration of metal framing member.	Mortar, nominal 1/2" thick, Type N or Type S meeting ASTM C270. "Scratch" surface when somewhat firm.

Wall System	Water Resistive Barrier	Lath	Fastening	Scratch Coat
<p>"Open Stud" construction Wood or steel, no more than 16" O.C</p> <p>No sheathing or Insulation Board only (open studs):</p> <p>Note: Non-rigid insulation board over rigid sheathing is limited to max 1/2" thick.</p>	Minimum two separate layers WRB. See Water Resistive Barrier, Page 8.	3.4 lb. self-furring 3/8" ribbed corrosion-resistant lath (ASTM C 847) Or 18 gauge woven wire mesh (ASTM C 1032) Or Alternate lath acceptable with a product evaluation acceptance report showing compliance to ICC-ES AC 275.	Corrosion resistant fasteners (ASTM C 1063) minimum 3/4" nail penetration into wood framing member, or minimum 3/4" staple penetration into wood framing member, or minimum 3/8" penetration of metal framing member.	Mortar, nominal 1/2" thick, Type N or Type S meeting ASTM C270. "Scratch" surface when somewhat firm.

Wall System	Water Resistive Barrier	Lath	Fastening	Scratch Coat
<p>Clean Concrete, Masonry / CMU, Stucco Scratch Coat (1st layer of cement plaster), or Stucco Brown Coat (2nd layer of cement plaster).</p> <p>Note: walls / surfaces must be clean and free from release agents, paints, stains, sealers, or other bond-break materials, that may reduce strength of mortar adhesion.</p>	<p>Note: A WRB may be needed to prevent moisture from penetrating the wall.</p>	<p>Install lath if question or concern regarding ability of veneer to adhere to wall:</p> <p>2.5 lb. or 3.4 lb. self-furring 3/8" ribbed corrosion-resistant lath (ASTM C 847)</p> <p>Or</p> <p>18 gauge woven wire mesh (ASTM C 1032)</p> <p>Alternate lath acceptable with a product evaluation acceptance report showing compliance to ICC-ES AC 275.</p>	<p>If lath is applied, use corrosion resistant fasteners (ASTM 1063).</p>	<p>If a scratch coat is required use a nominal 1/2" thick, Type N or Type S mortar, meeting ASTM 270.</p> <p>"Scratch" surface when somewhat firm.</p>

Wall System	Water Resistive Barrier	Lath	Fastening	Scratch Coat
<p>Existing Concrete, Masonry / CMU, Stucco, or Brick (structurally sound) (e.g. painted or not clean)</p>	<p>Note: A WRB may be needed to prevent moisture from penetrating the wall.</p>	<p>2.5 lb. or 3.4 lb. self-furring 3/8" ribbed corrosion-resistant lath (ASTM C 847)</p> <p>Or</p> <p>18 gauge woven wire mesh (ASTM C 1032)</p> <p>Alternate lath acceptable with a product evaluation acceptance report showing compliance to ICC-ES AC 275.</p>	<p>If lath is applied, use corrosion resistant fasteners (ASTM 1063).</p>	<p>If a scratch coat is required use a nominal 1/2" thick, Type N or Type S mortar, meeting ASTM 270.</p> <p>"Scratch" surface when somewhat firm.</p>

Wall System	Water Resistive Barrier	Lath	Fastening	Scratch Coat
<p>Metal Buildings or other surfaces / wall construction not listed above.</p> <p>See manufacturer for recommendations regarding sheathing.</p>	<p>See manufacturer for recommendations.</p>			

Workmanship

This Installation Guide assumes that construction personnel have knowledge of the materials described and their proper methods of installation.

Prior to commencing activity related to the scope of this Guide, review all adjacent products and other subcontractor's work that precedes the installation of ACMV to ensure that proper workmanship is reflected and that there are no recognizable errors or deficiencies.

Building Code Requirements

Building code requirements vary from area to area. Check with local authorities for building code requirements for your area and application. Carefully read all sections of this guide and follow the manufacturer's Installation Instructions before proceeding with your ACMV application. In the event the manufacturer's Installation Instructions conflict with the intent of statements made in this document, contact the manufacturer for additional guidance.

Project Site Requirements

Always follow proper job site safety requirements when installing ACMV. Follow all OSHA requirements when installing ACMV products.

Material Requirements

Flashing

All flashing and flashing accessories must be corrosion resistant materials and integrated with the WRB materials. Flashing must be installed at all through wall penetrations and at terminations of ACMV installations.

Rainscreen Drainage Plane Systems (Optional)

Rainscreen building techniques have been used in construction for many years. These techniques are typically used to improve the escape of incidental water and decrease drying time. Rainscreen products (such as drainage mats or formed polymer sheeting) or construction techniques (such as strapping or furring) that create a capillary break/air space between the cladding and the primary water resistive barrier can be effectively incorporated into ACMV applications. Refer to the rainscreen / drainage system manufacturer's recommendation for applications with adhered concrete masonry veneer wall systems. Building codes may allow a single layer of WRB when a designed drainage space is incorporated in the wall system (i.e. rain screen).

Weep Screed

Weep screeds must be of corrosion resistant metal - minimum 0.019 inches or a minimum No. 26 gage, or a plastic weep screed minimum 0.050", and with a minimum vertical attachment flange of 3 1/2" wide.

Lath

The MVMA recommends using the following lath materials:

- 2.5 lb/yd² self-furred metal lath meeting ASTM C847
- 3/8" rib, 3.4 lb/yd² self-furred metal lath meeting ASTM C847
- 18 gauge (or heavier) woven wire mesh meeting ASTM C1032
- Other approved lath may be acceptable for use with ACMV provided the lath meets an appropriate ASTM standard or
- The lath product is consistent with the ACMV manufacturer's installation instructions and has an evaluation acceptance report from an ANSI Accredited Evaluation Service showing compliance with ICC-ES Acceptance Criteria 275 (AC275).

All lath and lath accessories must be made of corrosion resistant material. All lath material must be self-furred or use self-furring fasteners. Refer to the Summary Table on page 4 and 5 for specific lath and fastener recommendations.

Fasteners

Corrosion resistant fasteners are used to secure flashing and lath. A variety of fasteners are available such as staples, screws, and nails. For specific fastener selective criteria, refer to ASTM C1063 Sec. 7.10.2.

- **Wood framing** - Corrosion resistant staples, corrosion resistant roofing nails, or corrosion resistant screws and washers, all to be of sufficient length to penetrate a minimum of 3/4 inch into framing members.
- **Metal framing or panels** - Corrosion resistant, self-tapping screws with sufficient length to penetrate 3/8 inch through metal studs or panels, with heads or washers large enough to not pull through lath.
- **Masonry walls or panels** - Corrosion resistant concrete screws or powder actuated fasteners (or cap fastener), with heads or washers large enough to not pull through lath.

Mortar

Any of the following mixes may be used:

Mix 1:

- 1 part portland Cement (ASTM C150)
- 1 part Lime (ASTM C207)
- 4.5 parts Sand (ASTM C144)
- potable water

Mortar (continued)

Mix 2:

- 1 part Type S Masonry Cement (ASTM C91)
- 2.25 parts Sand (ASTM C144)
- potable water

Mix 3:

- 1 part Type N Masonry Cement (ASTM C91)
- 2.25 parts Sand (ASTM C144)
- potable water

Premix Mortar

- Premixed mortars must meet the requirements of ASTM C270 for Type N or Type S. Check with the mortar manufacturer to determine if the premixed mortar is suitable for installation of adhered concrete masonry veneer and it meets building code requirements of 50 psi shear bond when tested in accordance with ASTM C482.

Check with the ACMV manufacturer on additional requirements and recommendations if using color pigments, integral bonding agents, or other admixtures in your mortar mix.

Mortars mixed with higher amounts of sand will tend to be less workable. Mortar mixed with higher amounts of cement will provide a greater bond strength but may be prone to increased dry-shrinkage cracking. Type N mortars are generally easier to grout with than Type S. For the scratch coat, installation of ACMV, and grouting, Type N or Type S mortar meeting the above requirements are acceptable.

The use of polymer modified mortar designed for the installation of adhered manufactured stone veneer provides benefits beyond traditional ASTM C270 Type S or Type N mortar. The appropriate use of polymer modified mortars, polymer modifiers, or bonding agents provide additional assurance proper bond is achieved.

When considering mortar selections follow the stone manufacturer's recommendations regarding the use of polymer modified mortar for challenging installations or where increased bond strength is desired. Examples of these installations include, but are not limited to: tight-fit applications, tilt-up construction, direct bond to CMU, or hot weather conditions.

Polymer modified mortar intended for installation of adhered manufactured stone veneer and meeting the requirements of ANSI 118.4 is acceptable. Check with the mortar manufacturer for acceptable use of the mortar. Bond enhancing modifiers or bonding agents, if used, must comply with the requirements of ASTM C1384.

Polymer modified mortars, modifiers, and bonding agents must be used in strict accordance with the mortar or additive manufacturer's recommendations.

Surface Preparation

Walls and Wall Systems

Verify structural and surface integrity of existing wall prior to installation. ACMV units must only be applied to structurally sound walls or structures.

Wall systems shown in the details (drawings) on pages 10 thru 45 of this Guide are wood frame with rigid sheathing unless otherwise noted. Adhered Concrete Masonry Veneer may be successfully applied to other walls or wall systems that include standard wood and metal framing, rigid sheathing, or cementitious stucco scratch or brown coat that has not been slicked or burned.

Other wall systems, or structures may be acceptable with qualifications:

- **Masonry walls, poured-in-place concrete walls, and concrete tilt up panels** must be free of dirt, waterproofing, paint, form oil, or any other substance that could inhibit the mortar bond. These surfaces must have a rough texture to ensure a mortar bond. Acid washing, sand/bead blasting, pressure washing, or a combination of these methods may be necessary to achieve the required bondable surface. If a bondable surface cannot be achieved, attach lath and scratch coat before installing ACMV.
- **Existing masonry surfaces** must be evaluated for mortar and face integrity and must be free of dirt, waterproofing, paint, or any other substance that could inhibit the mortar bond. Surfaces may be cleaned by pressure washing, acid washing, sand/bead blasting, or a combination of these methods to achieve a bondable surface. If the surface cannot be cleaned, attach lath before applying the mortar scratch coat.
- **Open studs, non-rigid sheathing and metal siding** must be prepared with 3.4 lb paper backed lath with a minimum ½" thick scratch coat and allowed to cure for a minimum of 48 hours prior to ACMV installation.

Wall Systems with Exterior Rigid Continuous Insulation.

ACMV may be installed on walls insulated with continuous insulation such as rigid foam insulation. Lath attachment methods described in this Guide are generally considered acceptable when ACMV is installed over continuous insulation up to ½" thick. Installation of ACMV over continuous insulation greater than ½" thick generally requires an engineered fastening system.

The Foam Sheathing Committee of the American Chemistry Council (www.americanchemistry.com) has published a "Guide to Attaching Exterior Wall Coverings through Foam Sheathing to Wood or Steel Wall Framing" that may provide guidance when engineering a fastening system for ACMV (<http://fsc.americanchemistry.com/Building-Code/Installation-of-Cladding/Guide-to-Attaching-Exterior-Wall-Coverings.pdf>).

Wall Systems with Exterior Rigid Continuous Insulation. (continued)

MVMA suggests consulting the Foam Sheathing Committee's technical guidance regarding fastening recommendations for ACMV installed over thick rigid foam insulation on framed walls. Also see the "Fasteners" section of this Guide (page 6).

Wall systems outside the scope of this document which may require a specifically-designed installation system for ACMV:

- Structural Insulating Panels (SIPs)
- Insulating Concrete Forms (ICFs)

Wall systems with these substrates are considered unacceptable for the application of ACMV:

- Existing siding in unsound condition
- Exterior Insulation Finishing System (EIFS)
- Deteriorating or unsound masonry surfaces.

Water Resistive Barrier

Where a WRB is required, the MVMA recommends installing two separate layers in shingle fashion, starting from the bottom of the wall. The inner layer of WRB should be installed, along with flashings, to create a drainage plane. The outer layer of WRB is intended to keep the scratch coat from contacting the inner layer of WRB. The upper layer of the WRB should lap on top of the lower layer by a minimum of two inches. The vertical joints of the WRB must be lapped a minimum of six inches. Inside and outside corners must be overlapped a minimum of 16" past the corner in both directions. The WRB should be installed in accordance with the manufacturer's recommendations and be integrated with all flashing accessories, adjacent WRBs, doors, windows, penetrations, and cladding transitions.

Acceptable WRBs:

- Minimum two separate layers of any of the following: No. 15 felt complying with ASTM D226 for Type 1 felt, or Grade D paper (ICC-ES AC38), or house wrap (ICC-ES AC 38), or any combination two separate layers of these materials. One layer paper-backed lath meeting requirements for Grade D paper may be substituted for the outer layer.
- Rigid continuous insulation may be substituted for the inner layer of WRB provided it is installed and sealed and/or taped in accordance with the insulation manufacturer's installation instructions and has an evaluation acceptance report from an ANSI Accredited Evaluation Service recognizing it as a WRB. Rigid continuous insulation is commonly applied on the exterior side of the framing or on the exterior side of sheathing, runs continuously, and has minimal thermal bridging.

Lath

Metal lath should be applied horizontally per manufacturer's instructions, and should overlap a minimum of one inch on the horizontal and vertical seams. The ends of adjoining lath places should be staggered. Metal lath is usually installed with the lath "cups" facing up. With the cups up, the lath feels rough when sliding the hand up the lath, and feels smooth when sliding the hand down the lath.

Lath should be wrapped around inside and outside corners to the next stud. Lath should be fastened every six inches vertically on each stud or similar spacing on concrete wall surfaces. Do not end lath at corner framing. It is preferred that lath fasteners do not penetrate through the exterior sheathing between the studs.

Alternate lath should be installed per the manufacturer's instructions.

Flashings/Weep Screeds/Casing Bead/Movement Joints

The weep screed should be corrosion resistant metal minimum 0.019-inch or No. 26 galvanized sheet gage, or a plastic weep screed minimum 0.050", and with a minimum vertical attachment flange of 3 ½" wide.

All flashing and metal detail pieces should be manufactured of corrosion resistant material.

Verify that all flashing, including roofing kickout flashing, has been properly installed. Although roof flashings are not part of the wall cladding system, they are necessary for proper moisture management. Flashing material should extend above horizontal terminations, roofing material, and drainage planes or drainage products.

All flashing material should be integrated with water resistive barriers to prevent moisture penetration into structure. The WRB should overlap the weep screed flange.

* **Movement Joints** -Do not install ACMV over these joints.

Clearances

- On exterior stud walls, weep screeds and other base flashings should be held a minimum of 4" above grade or a minimum of 2" above paved surfaces such as driveways, patios, etc. This minimum can be reduced to 1/2" if the paved surface is a walking surface supported by the same foundation supporting the wall.
- On exterior stud walls where the ACMV continues down a concrete or CMU foundation wall, and where a weep screed is incorporated into the wall-to-foundation transition, at the bottom maintain minimum 2" clearance from grade, or 1/2" clearance from a paved surface.

Clearances (continued)

- On exterior stud walls where the ACMV continues down a CMU foundation wall, with WRB and lath installed down to the weep screed at bottom, maintain minimum 4" clearance from grade, or 2" clearance from a paved surface.
- Where ACMV is applied over an exterior concrete or CMU wall, maintain 2" clearance from grade or 1/2" from a paved surface.
- Over an exterior concrete or CMU wall that is not enclosing conditioned space (e.g. landscape walls, pillars, columns, etc) maintain minimum 2" clearance from grade or 1/2" from a paved surface.

Interior Applications

Interior applications in non-wet locations (areas not exposed to moisture) for ACMV are similar to exterior applications with the following alternatives:

- Two layers of WRB are not necessary behind the lath and scratch coat. A single layer of WRB may protect moisture sensitive materials during ACMV installation.
- Cement backer board complying with ASTM C1325 may be substituted for other substrates (i.e. wall board or plywood), WRB, lath, and scratch coat. The cement backer board should be installed per the manufacturer's instruction. The ACMV should be installed per this Guide – see Grouted Adhered Concrete Masonry Veneer Application (page 8) or Tight Fitted Adhered Concrete Masonry Veneer (page 9) and the Mortar and Premix Mortar sections (page 7). Latex-Portland cement mortars complying with ANSI 118.4 may be used for installation of ACMV to cement backer board. Follow the mortar manufacturer's instructions.

Additional conditions for interior applications:

- Clearances at transitions of the ACMV to other materials or surfaces such as floors or ceilings should allow for potential differential movement, but the criteria in the Clearances section (page 8) are not necessary.
- Flashings, weep screeds, and casing beads are not necessary.

Installation of Adhered Concrete Masonry Veneer

Prior to commencing installation of ACMV, ensure that the WRB and flashing are properly installed and integrated with each other. Refer to the flashing details, referenced in this Guide, for detailing around windows, doors, through-wall penetrations, and ACMV terminations.

Before installing ACMV, lay out a minimum of 25 square feet at the jobsite so there is a variety of sizes, shapes, and colors from which to choose. Mixing ACMV sizes, shapes, textures and color will allow for variety and contrast in the design to achieve the desirable finished project.

Mortar Scratch Coat

After the lath is installed, apply a nominal 1/2" thick layer of mortar ensuring the lath is completely encapsulated with mortar. The mortar should be applied with sufficient pressure and thickness to fully embed the lath in mortar. Once the mortar is thumbprint hard, scratch (score) the surface horizontally to create the mortar scratch coat.

Moist curing the mortar scratch coat will help reduce cracking and ensure proper hydration during curing. Before applying ACMV, the mortar scratch coat should be dampened so that the surface appears wet but free of standing water.

Grouted Adhered Concrete Masonry Veneer Application

Tip: Installing ACMV from the top down will minimize cleanup requirements.

Prior to the application of mortar to the scratch coat or the back of the ACMV, the scratch coat and back of the ACMV should be moistened so that the surfaces appear damp but are free of standing water.

The back of each ACMV should be entirely buttered with mortar to a nominal thickness of 1/2". Cover the entire back of the ACMV, not just the perimeter. Buttered ACMV should be firmly worked onto the scratch coat and slid slightly back and forth or with a slight rotating motion to set the ACMV.

Achieve mortar squeeze out in a volume which results in a full setting bed which covers the scratch coat completely. As an alternative to the back-butter only method, mortar may be troweled onto the scratch coat, completely covering the scratch coat. Or both mortar application techniques may be combined.

With the proper mortar mix, moisture content, and scratch coat preparation, the installer will feel the mortar start to grab within a few seconds of the setting movement process. At this point, no further movement of that ACMV should be made as bonding will be broken. If the ACMV is inadvertently moved after initial set has begun, it should be removed, mortar scraped off the back of the ACMV and scratch coat, and then reinstalled following the application process.

Grouting the joints should be completed only after there is sufficient cure time of the installed ACMV units; when mild contact will not break the bonding. Grouting may be done with a grout bag, filling joints to the desired depth, ensuring that mortar is forced into all voids. Grout should be "thumbprint hard" before raking the joints. This curing time before the grout is ready will vary significantly with temperature and humidity. Use a wooden raking stick or pointed tool to rake the joints to the desired depth. Extra precaution should be taken while raking so the surface of the ACMV is not damaged. Clean off remaining grout debris on the ACMV surface with a dry, soft-bristled brush.

To prevent mortar smearing, DO NOT use a wet brush to treat uncured mortar joints.

Tight Fitted Adhered Concrete Masonry Veneer Application

The back of the ACMV and the scratch coat should be moistened with the surfaces appearing damp but free of standing water.

The back of each ACMV should be entirely buttered with mortar to a nominal thickness of 1/2". Cover the entire back of the ACMV, not just the perimeter. Buttered ACMV should be firmly worked onto the scratch coat and slid slightly back and forth to set the ACMV.

Achieve mortar squeeze out in a volume which results in a full setting bed which covers the scratch coat completely. As an alternative to the back-butter only method, mortar may be troweled onto the scratch coat, completely covering the scratch coat. Or both mortar application techniques may be combined.

With the proper mortar mix, moisture content and scratch coat preparation, the installer will feel the mortar start to grab within a few seconds of the setting movement process. At this point, no further movement of that ACMV should be made as bonding will be broken. If the ACMV is inadvertently moved after initial set has begun, it should be removed, mortar scraped off the back of the ACMV and scratch coat, and then reinstalled following the application process.

Tight fitted ACMV should be applied from the corners toward the middle of a wall, and from the bottom toward the top of the wall.

Cold Weather Application

ACMV applications should be protected from temperatures below 40 degrees F (4 degrees C). The use of anti-freeze admixtures to lower the freezing point of the mortar is not recommended. Accelerating admixtures shall comply with C1384; accelerating admixtures containing calcium chloride are not recommended. ACMV pieces containing visible frozen moisture shall not be installed.

The installation area should be sheltered and heated to keep the temperature above 40 degrees F (4 degrees C).

Hot Weather Application

If the environmental conditions during installation exceed 90 degrees F (32 degrees C) additional water may be needed on the scratch coated surface and the backs of the ACMV being applied. Providing shade and/or frequent misting of the wall may be required. Consult with mortar manufacturer to determine if mortar mix hot weather mix options are available. Local building code hot weather methods should be followed.

Cleaning the Adhered Concrete Masonry Veneer

Refer to ACMV manufacturer recommendations on cleaning and maintenance. Do not use harsh chemicals, such as acid, for cleaning, or use abrasive tools such as wire brushes or power washers.

Sealing Adhered Concrete Masonry Veneer

Refer to the ACMV manufacturer for recommendations regarding the use of sealants or topically applied water or graffiti-resistant coatings.

Alternative Installation Methods / Materials

MVMA is not in a position to offer guidance on non-standard installation methods or materials.

Example: Exterior installation methods using cementitious adhesive mortars with a direct application to a substrate which may include cement board and / or coatings applied as load-bearing bonded water-proof membranes.

MVMA recognizes new installation materials and methods not included in this Guide are presented to the market that affects our industry. Alternative installation materials and methods along with their test methods and evaluation criteria are being developed. As a designer, contractor, or installer, you may wish to utilize these materials and/or methods in lieu of the standard methods included in this guide. Verify the alternative method will meet or exceed standards for recommended installation practices.

Refer to manufacturers of the alternative installation methods / materials for additional information.

Cautions

The following precautions should be taken to ensure a successful and durable ACMV installation.

- Do not subject ACMV to direct or frequent water contact. For example, avoid allowing sprinklers to directly spray onto the surface. Also, downspouts or drainage pipes should be placed so that water is not frequently moistening the ACMV units.
- Do not subject ACMV to contact with de-icing materials, salt, or other harsh chemicals. Prolonged exposure to these conditions may discolor the ACMV or result in surface damage.

Fig. 1. Wall Assembly

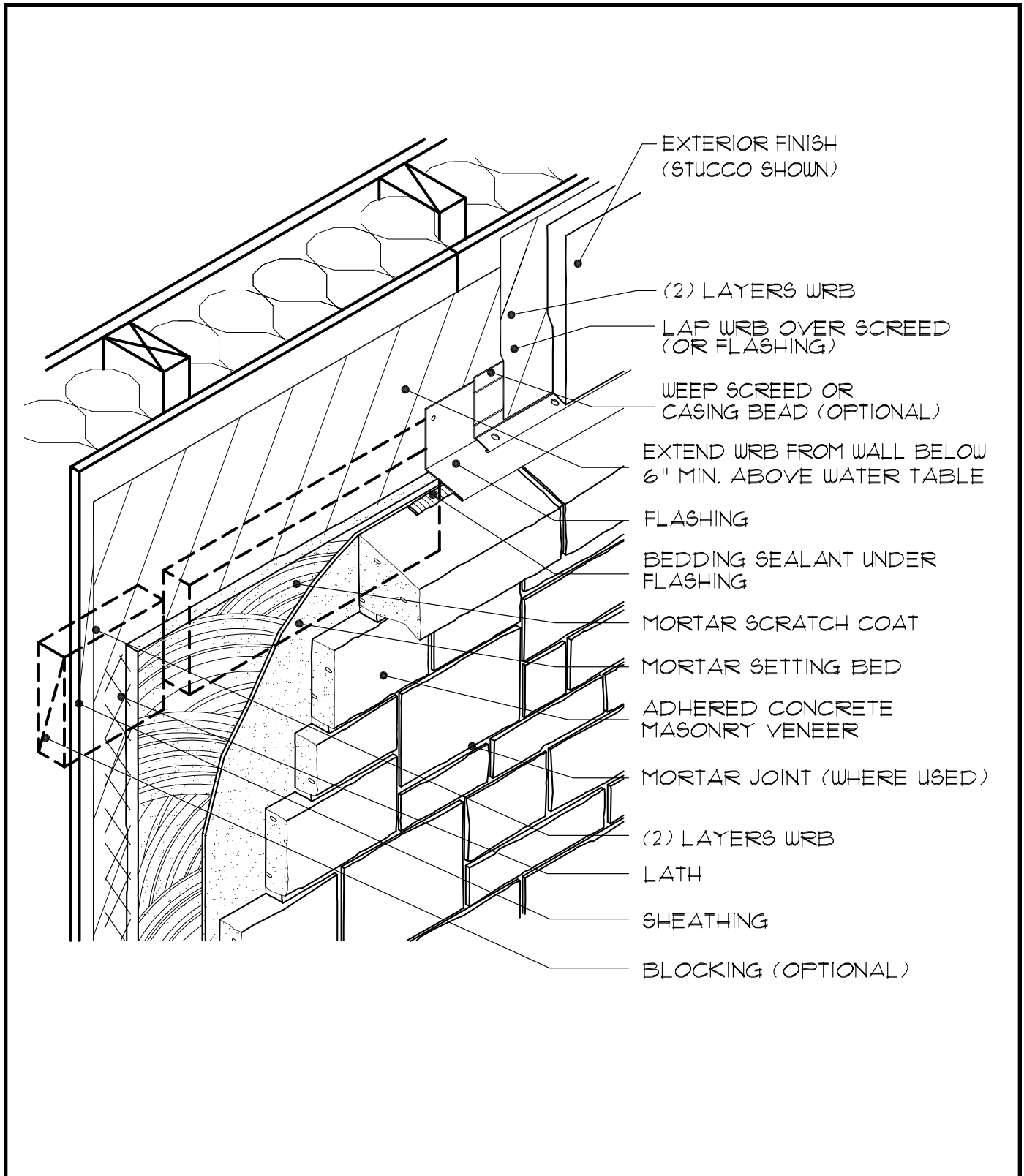
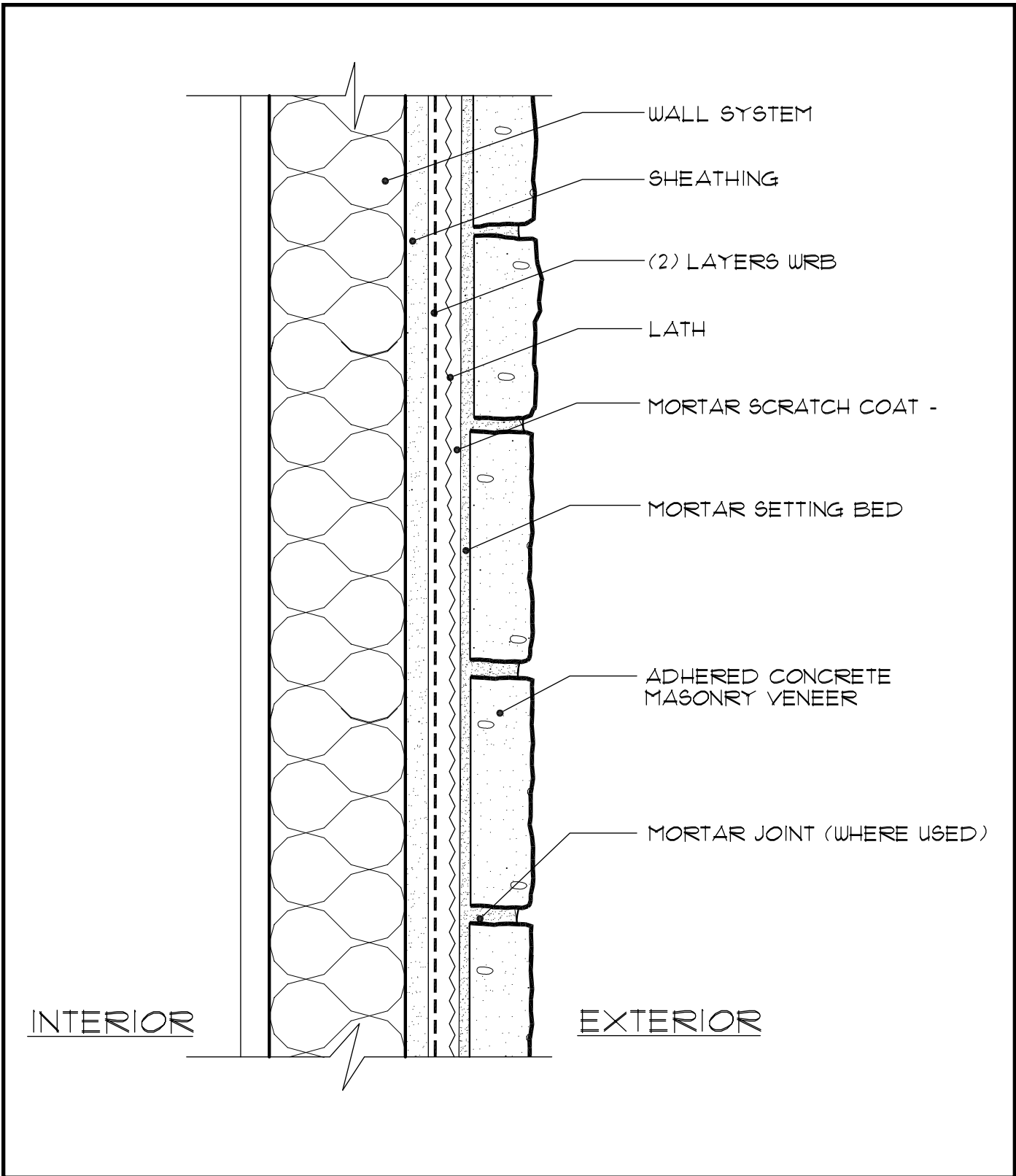
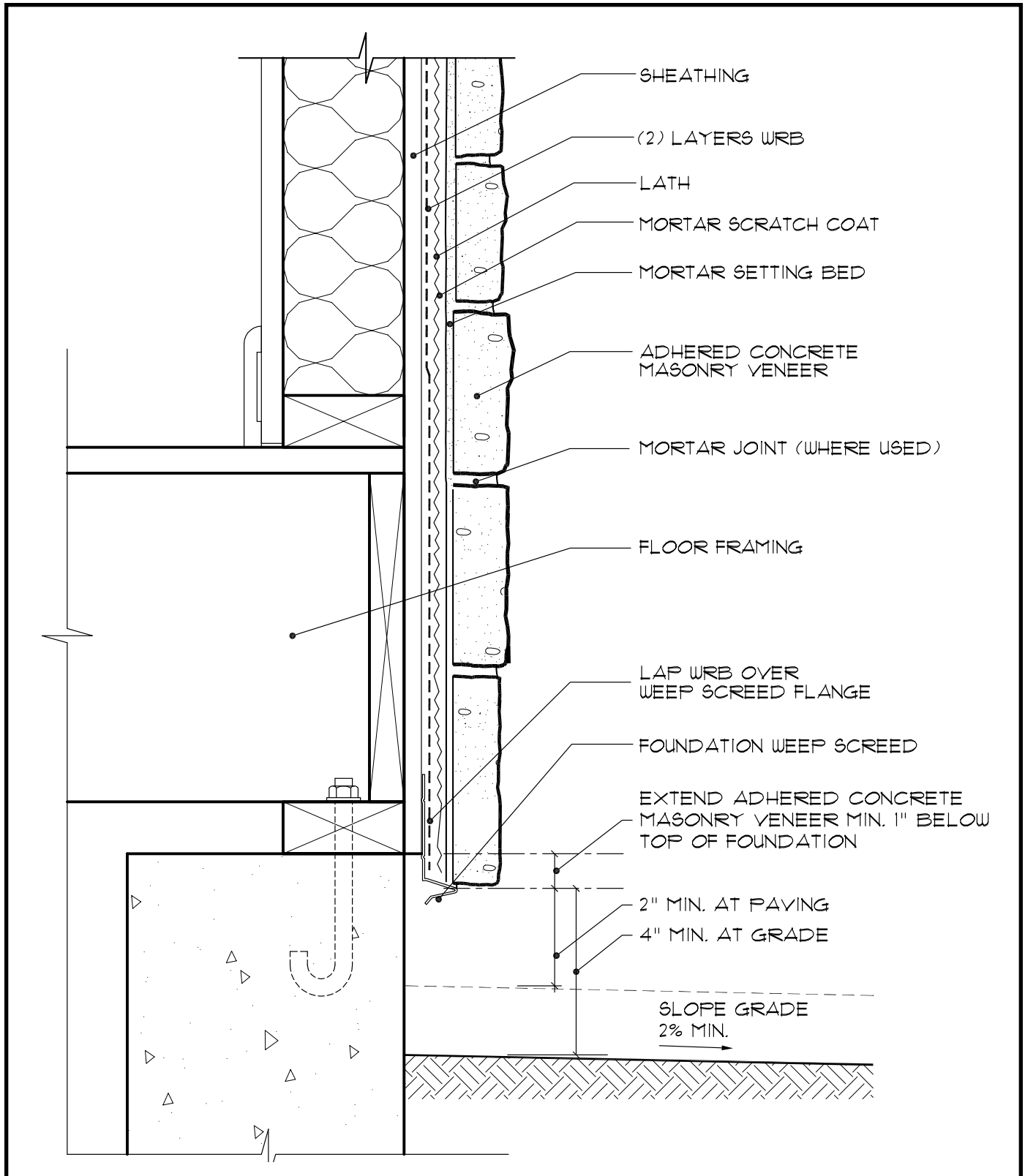

Fig. 2. Typical Wall Section



Note layering of sheathing, water resistive barrier, lath, scratch coat, and adhered concrete masonry veneer.

Fig. 3. Foundation Wall Base



A minimum 4" gap is required at the base of the stud wall to grade and a minimum 2" gap is required at base of the stud wall to a paved surface.

Fig. 4. Foundation Wall Base - ACMV Overlapping Foundation

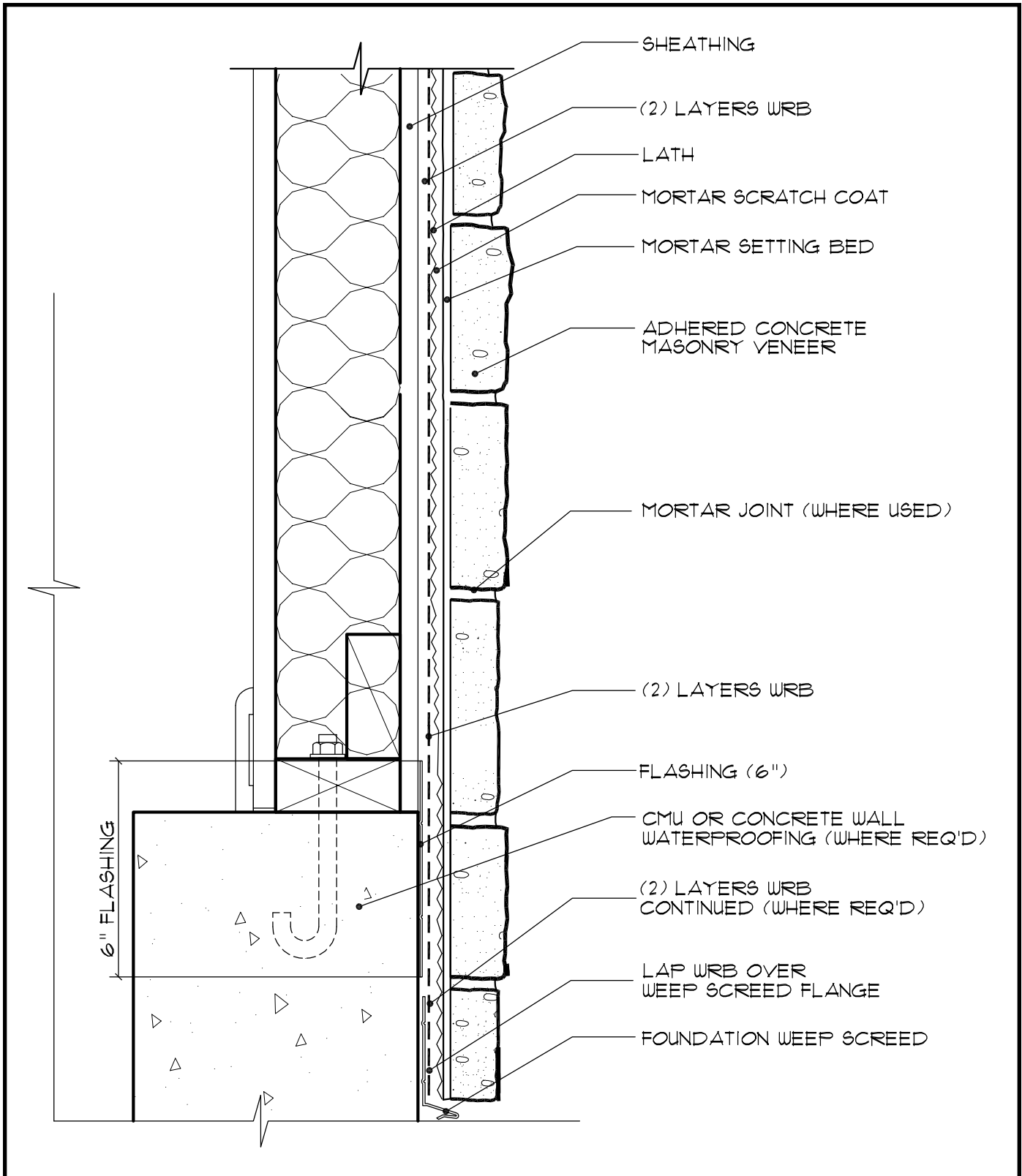

ACMV may overlap foundation wall with careful installation of flashing and WRB. This installation may continue down foundation wall to grade clearance.

Fig. 5. Foundation Wall - Transition to ACMV Continuing Down Foundation

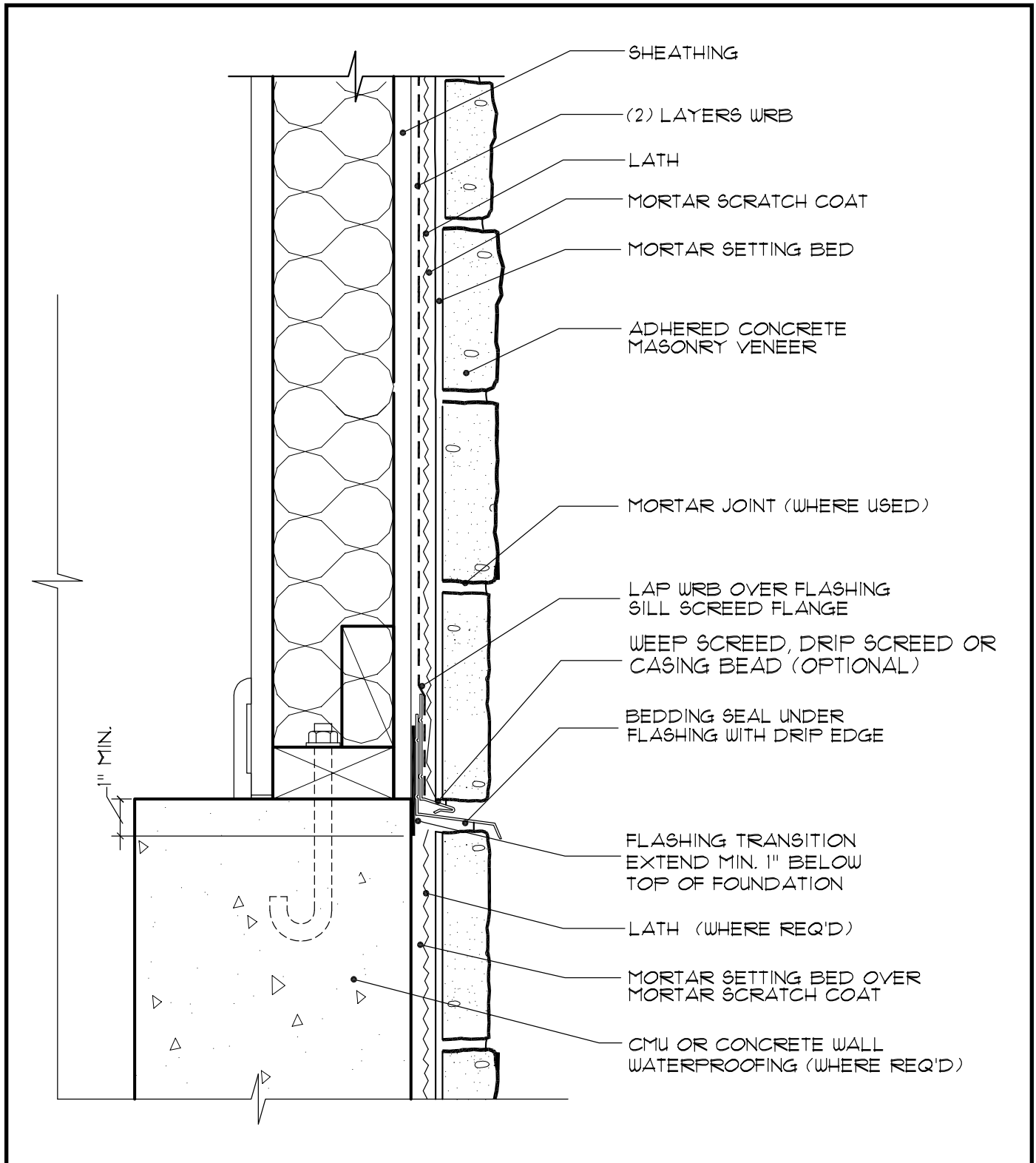

ACMV may continue down the foundation with the incorporation of a flashing transition with careful installation of WRB and flashing.

Fig. 6. Cladding Transition

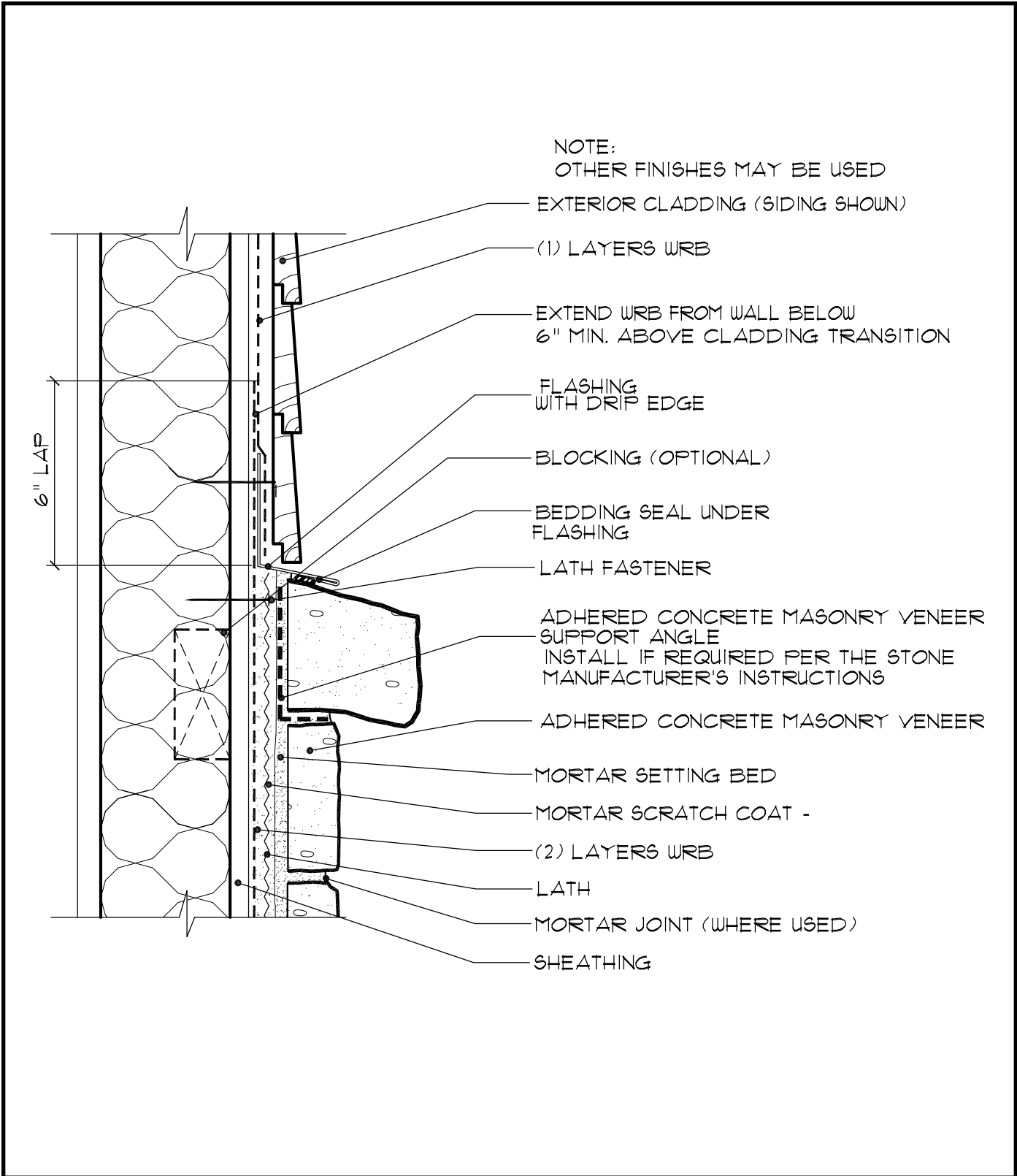

Flashing should be installed prior to the adhered concrete masonry. Water resistive barrier laps over the vertical leg of flashing for positive drainage. Optional support angle shown. Verify installation requirements with adhered concrete masonry veneer manufacturer.

Fig. 7. Outside Corner

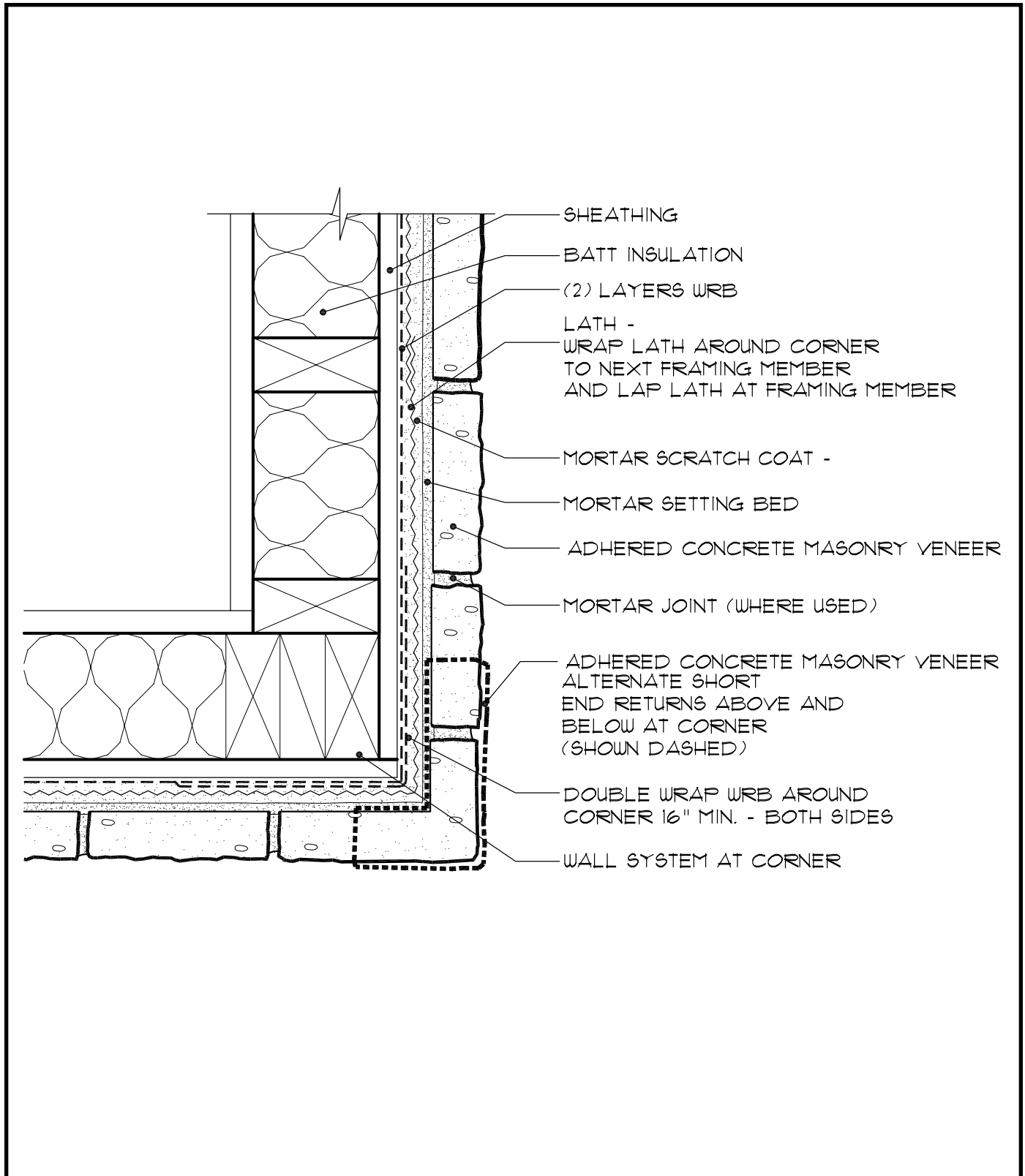

Randomly alternate short end returns above and below at the corner. Lap lath around the corner to the next framing member.

Fig. 8. Inside Corner

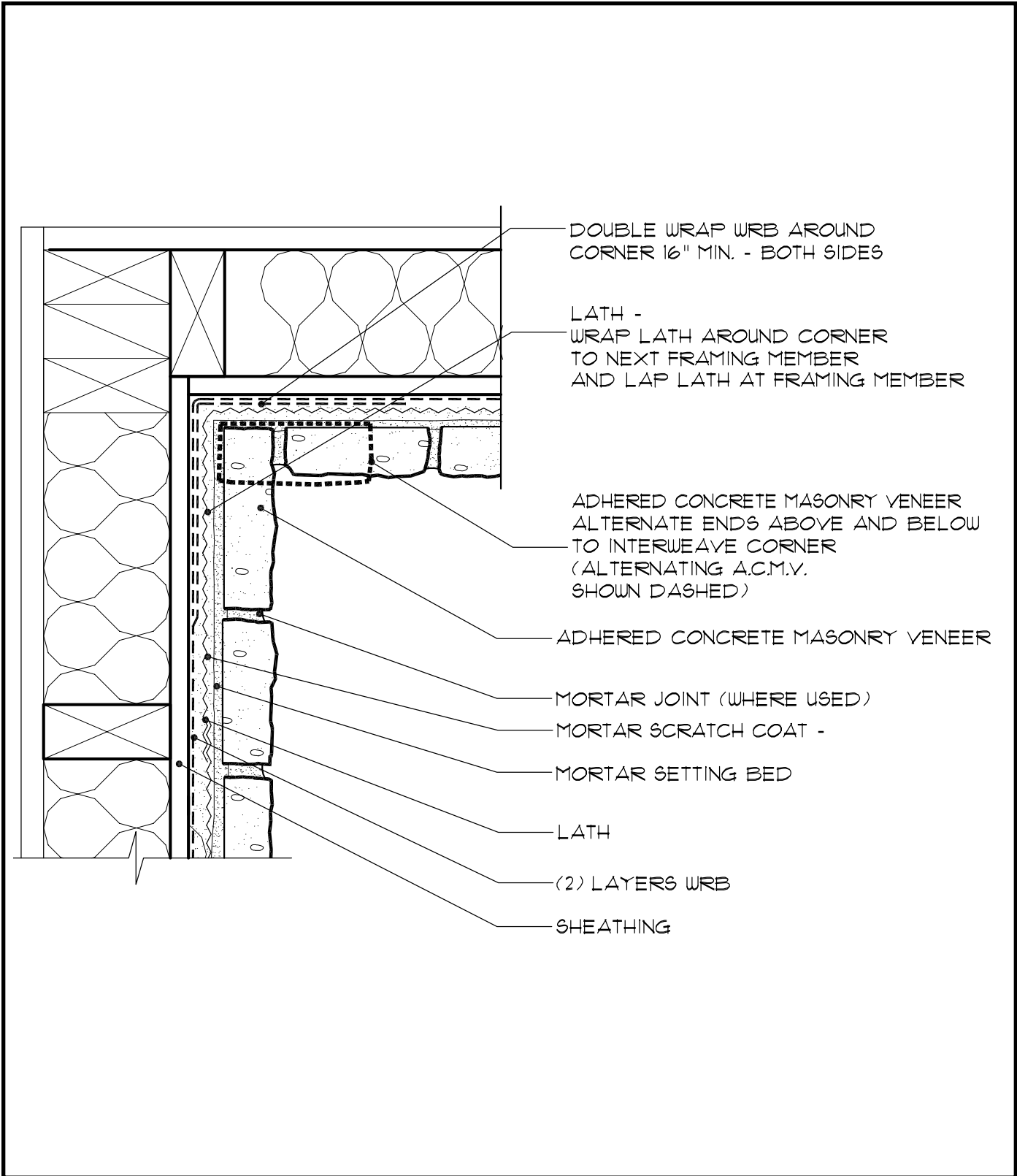

Randomly alternate ends above and below to interweave the corner. Double wrap water resistive barrier around both sides of the corner. Lap lath to the framing at least 16 inches to the next framing member.

Fig. 9. Horizontal Transition

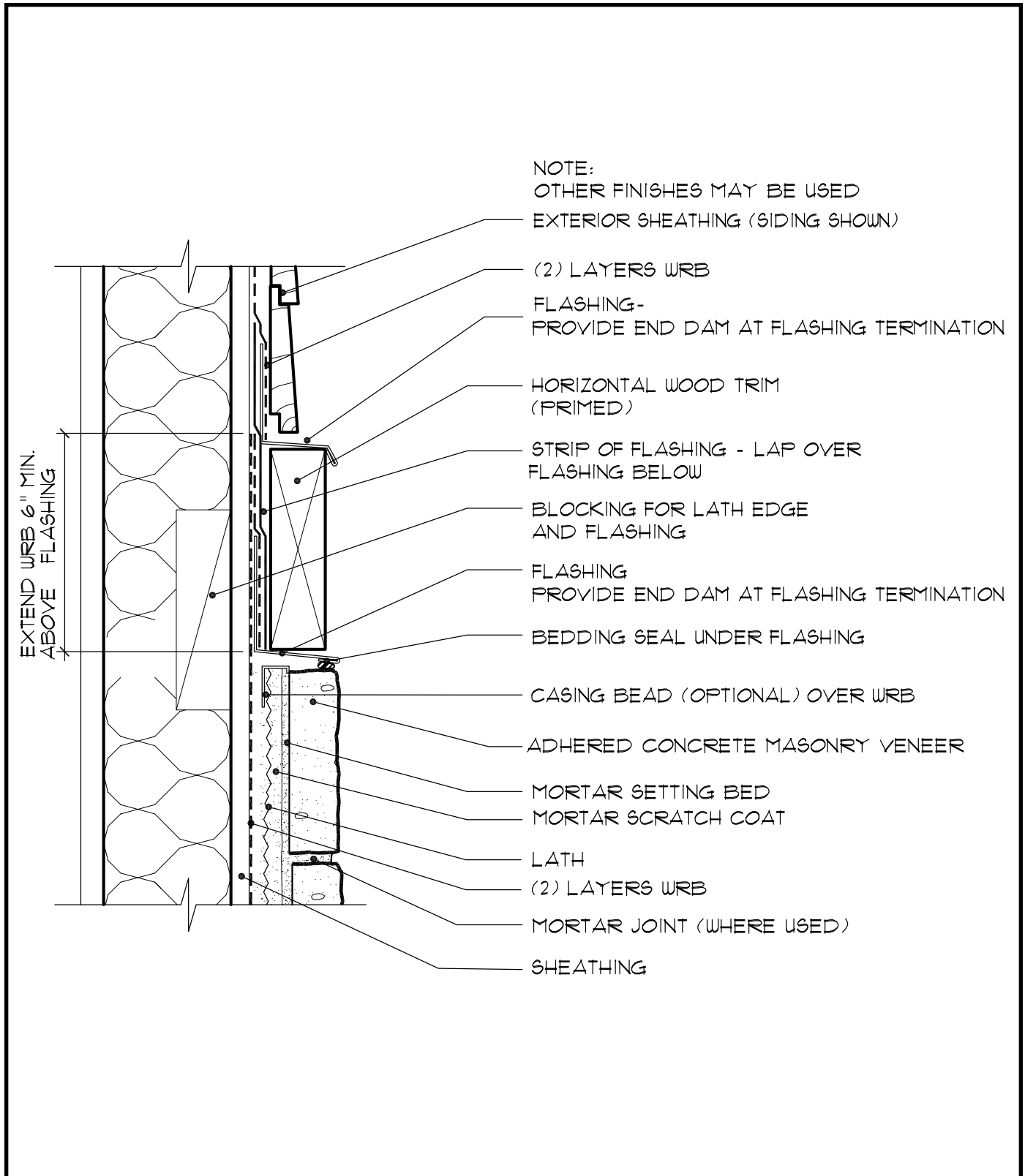

Note flashing is lapped shingle-fashion with corrosion resistant sheet metal. A bedding seal is used under the corrosion resistant sheet metal next to the adhered concrete masonry veneer.

Fig. 10. Vertical Transition

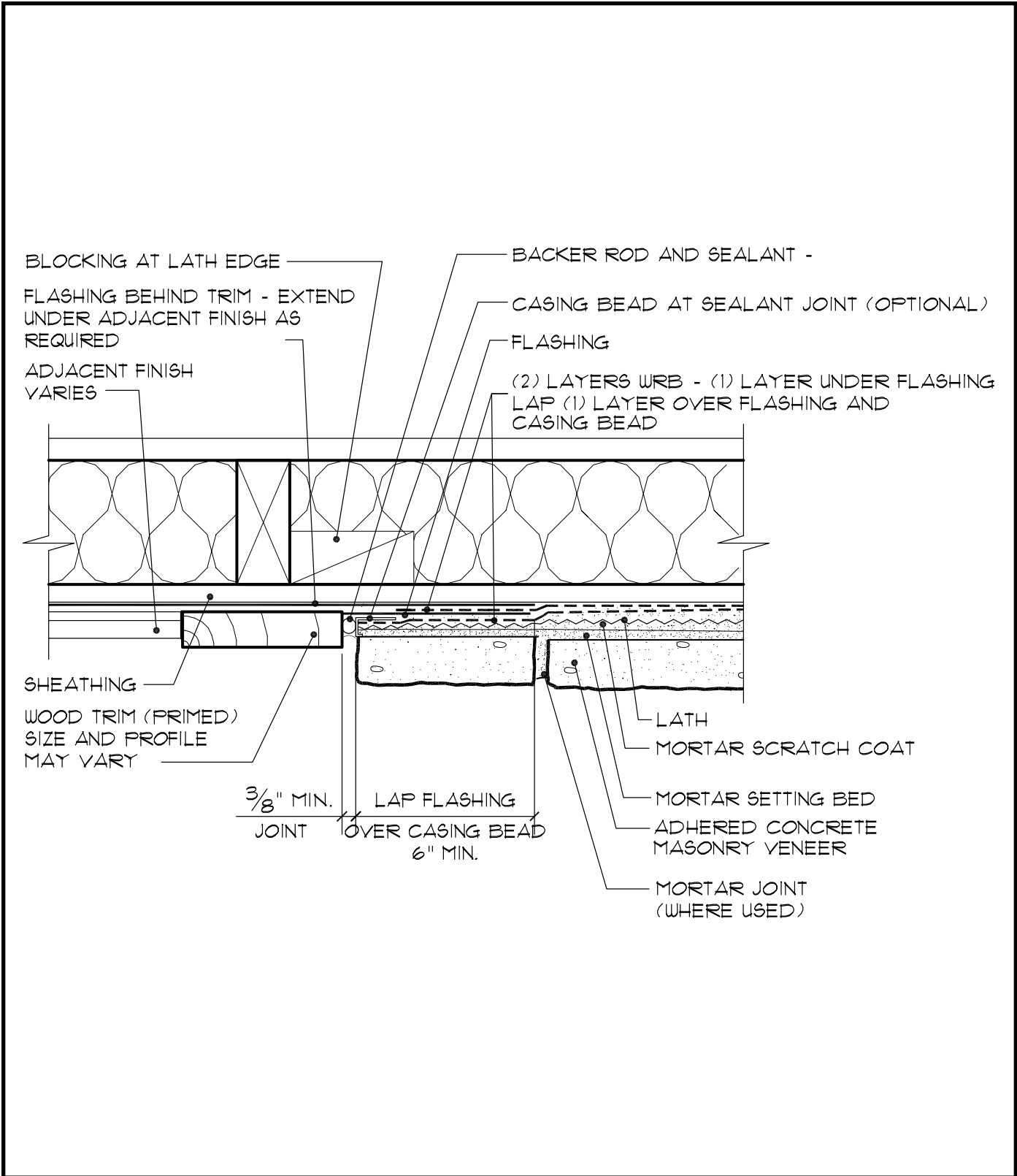

Flashing extends under the adjacent finishes. A 3/8" minimum gap should be used between finishes.

Fig. 11. Open Eave - Overhang

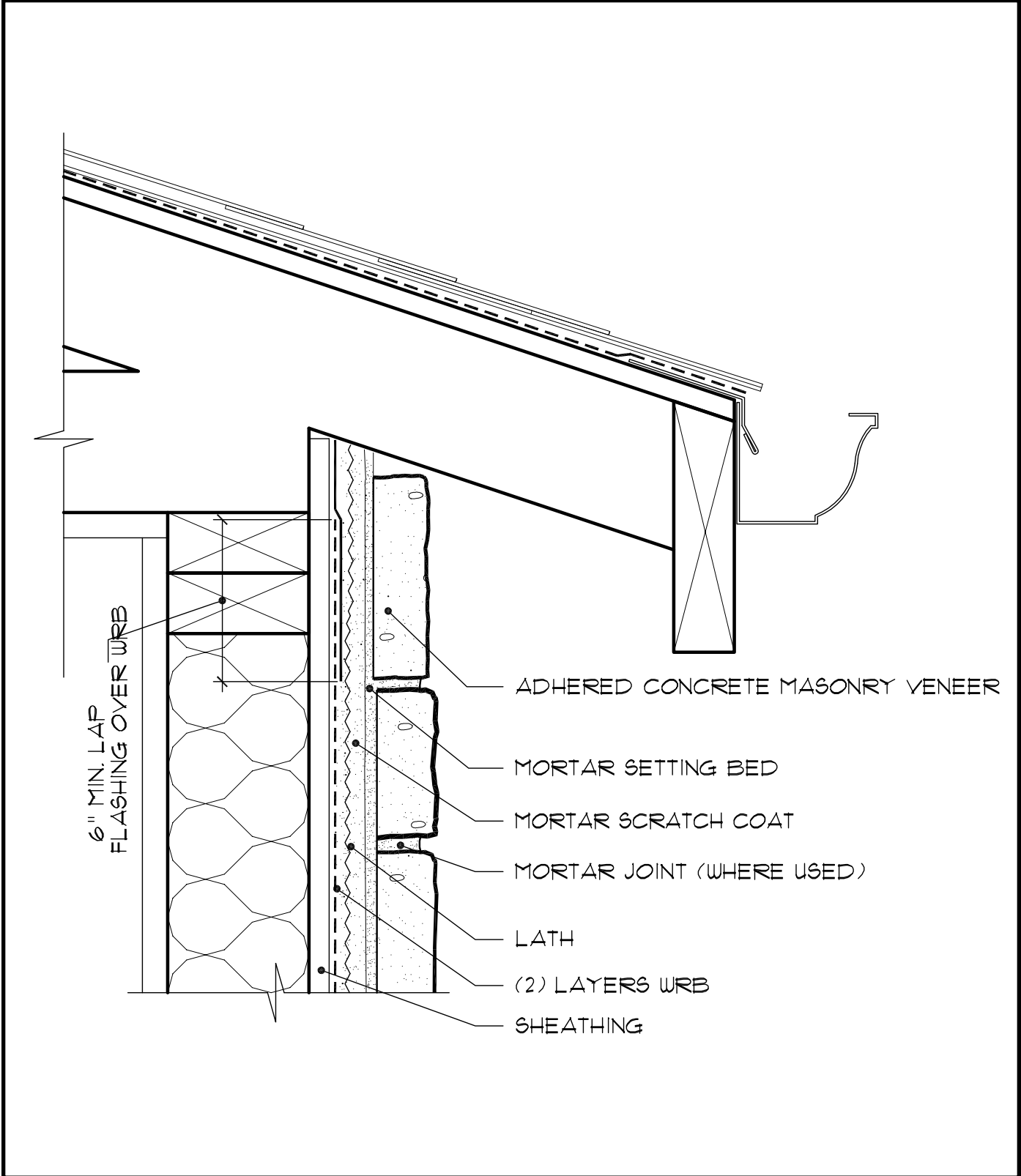

Water resistive barrier should be in place prior to soffit installation followed by adhered concrete masonry veneer.

Fig. 12. Open Eave - Flush

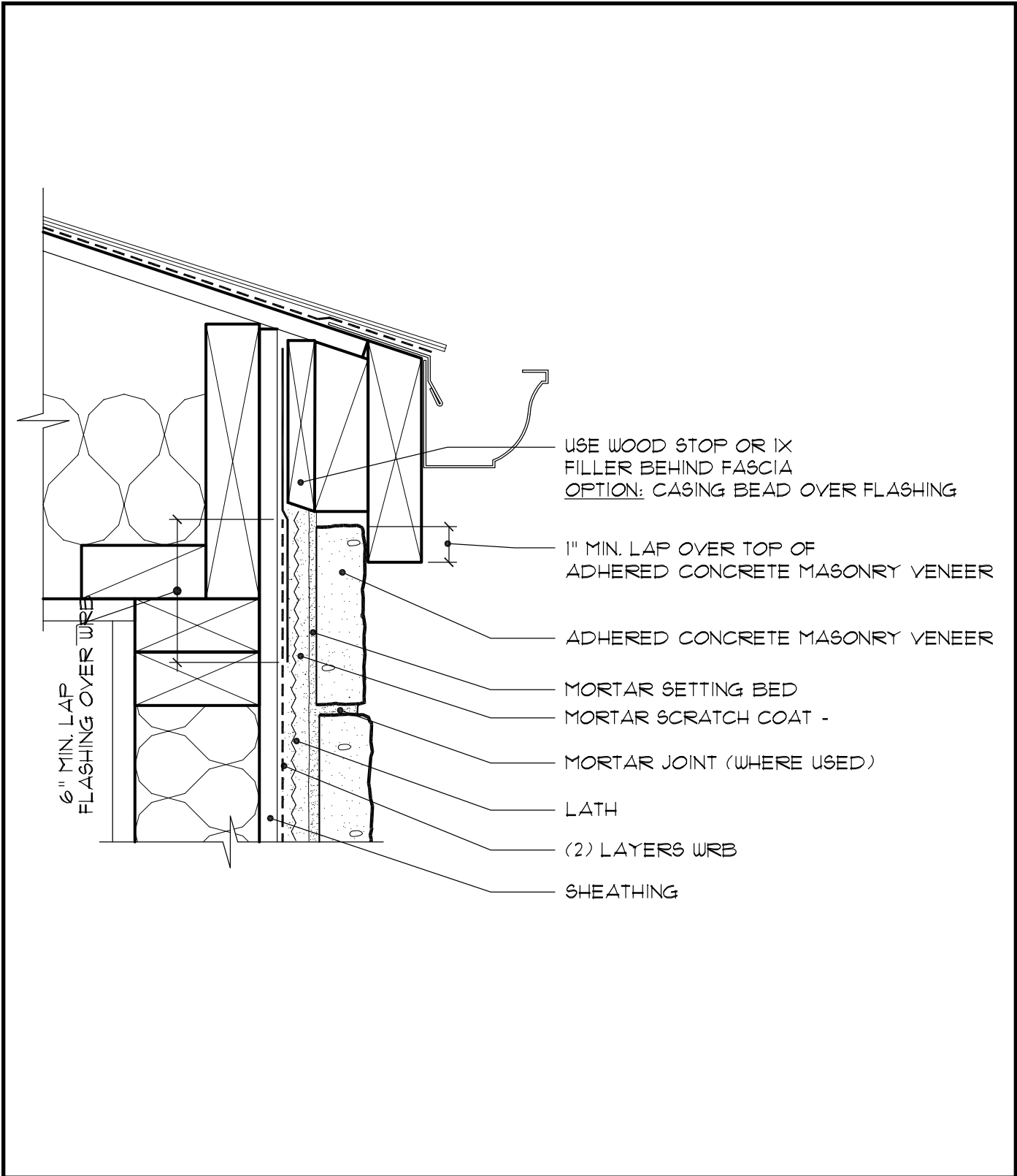

Water resistive barrier should be in place prior to soffit installation followed by adhered concrete masonry veneer

Fig. 13. Rake - Overhang

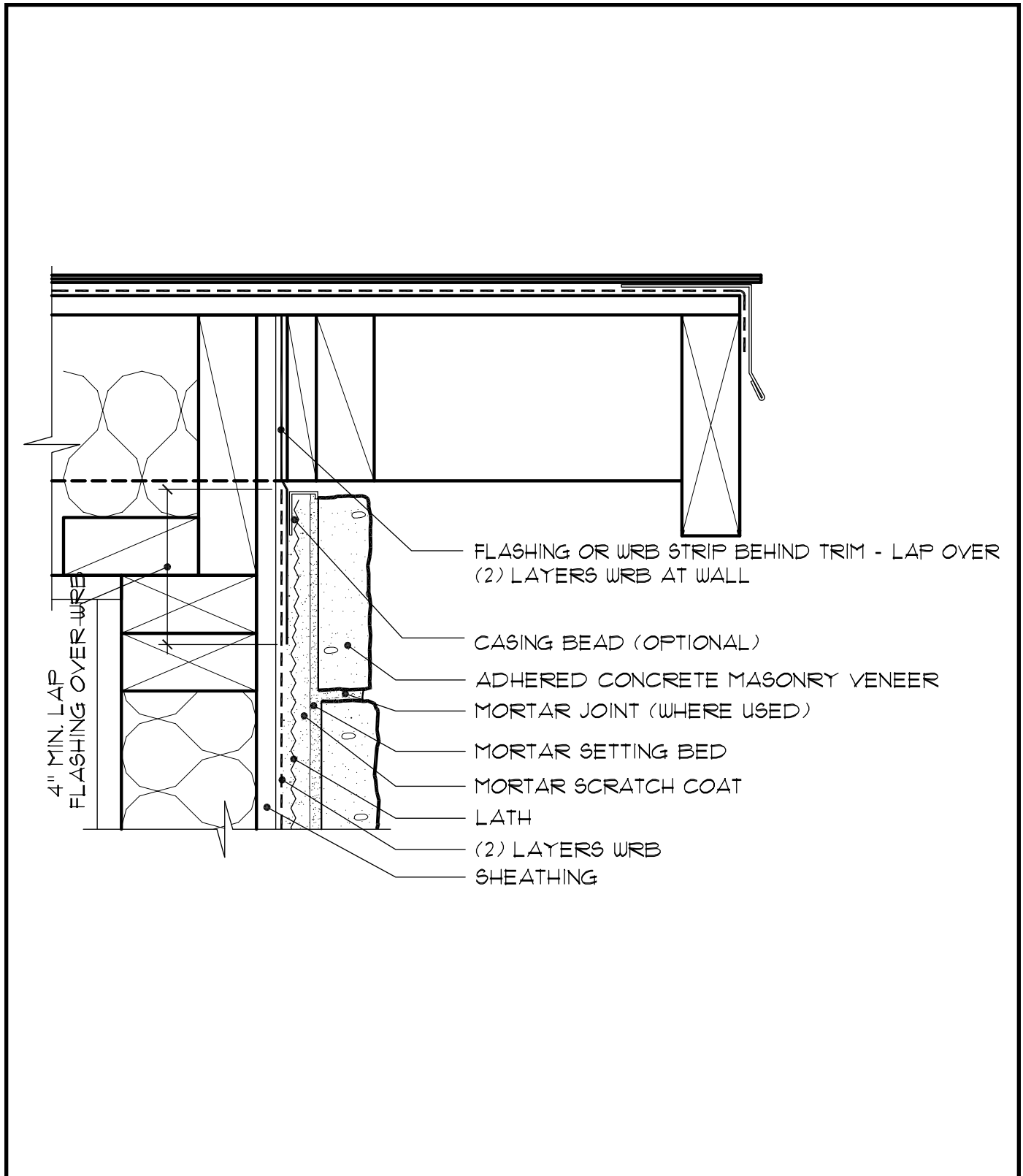

The intent of these details is to limit exposure to wind driven rain.

Fig. 14. Rake - Flush

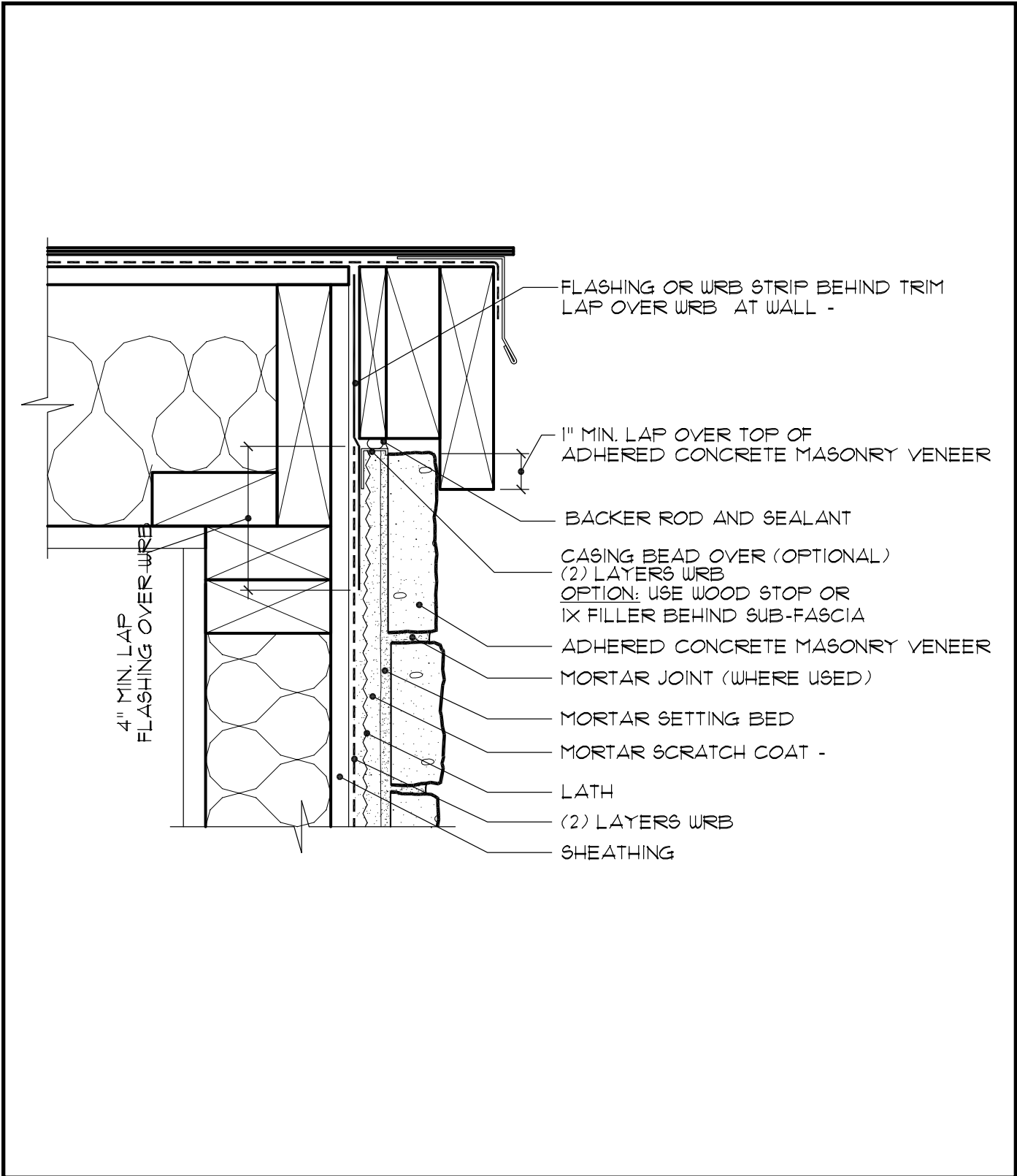

Note the use of backer rod and sealant.

Fig. 15. Side Wall - Composition Shingles

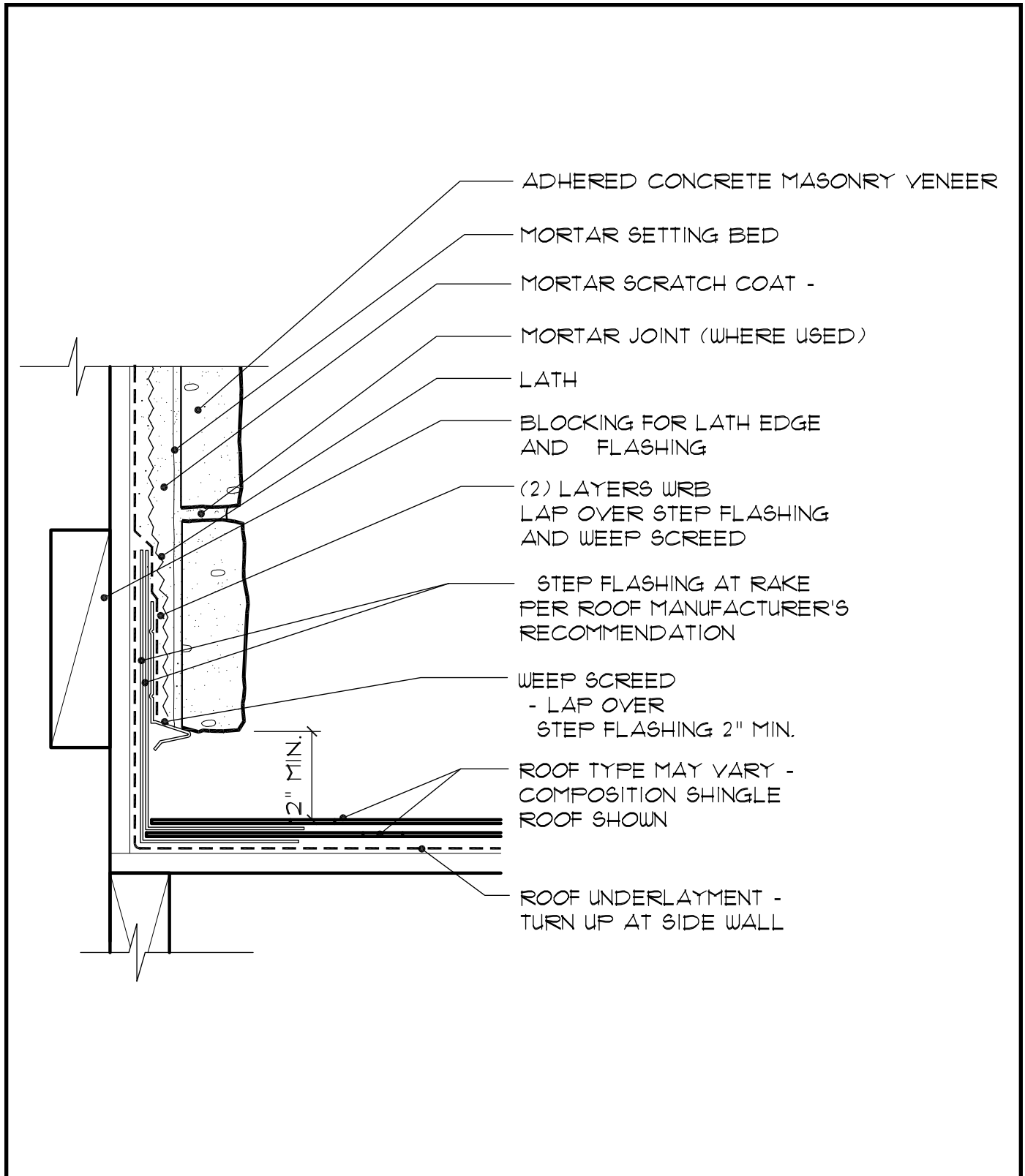

Water resistive barrier laps over step flashing and weep screed.

Fig. 16. Side Wall - Composition Shingles Curbing

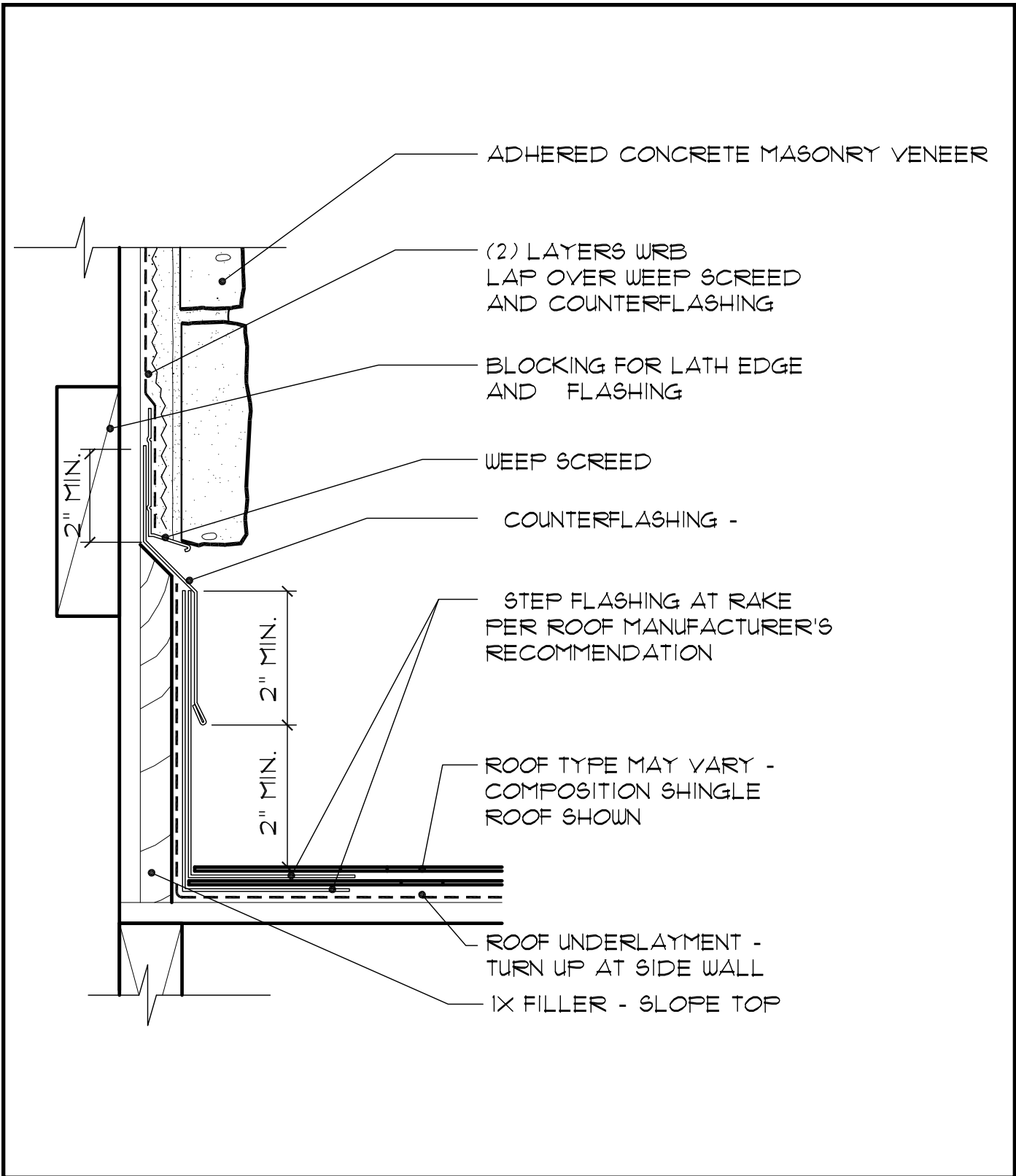

This detail includes base trim. Note the counterflashing between trim and adhered concrete masonry veneer.

Fig. 17. Side Wall - Tile Roofing

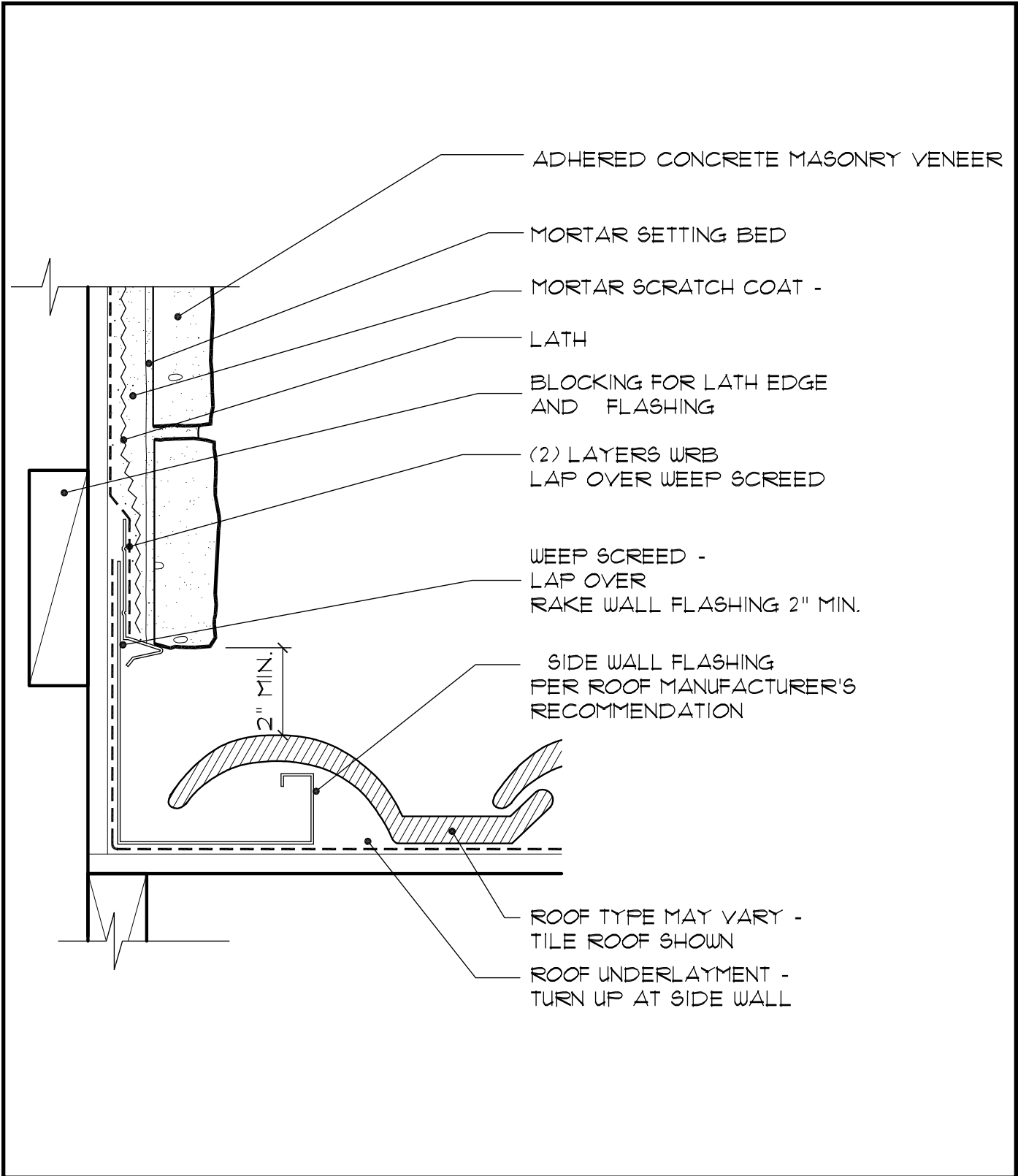

Water resistive barrier laps over step flashing and weep screed.

Fig. 18. Side Wall - Tile Roofing Curbing

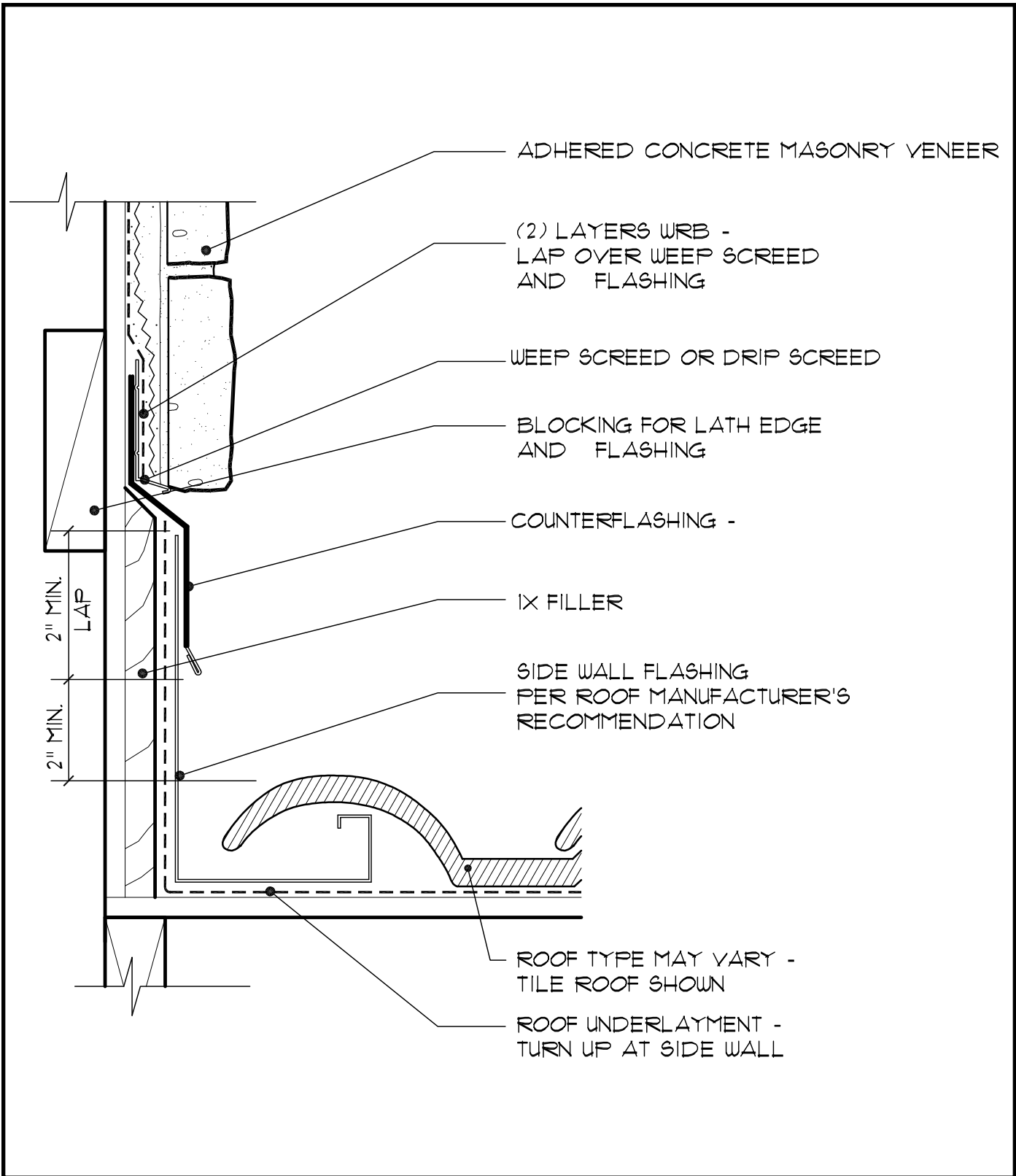

This detail includes curbing. Note the counterflashing between trim and adhered concrete masonry veneer.

Fig. 19. Window Sill

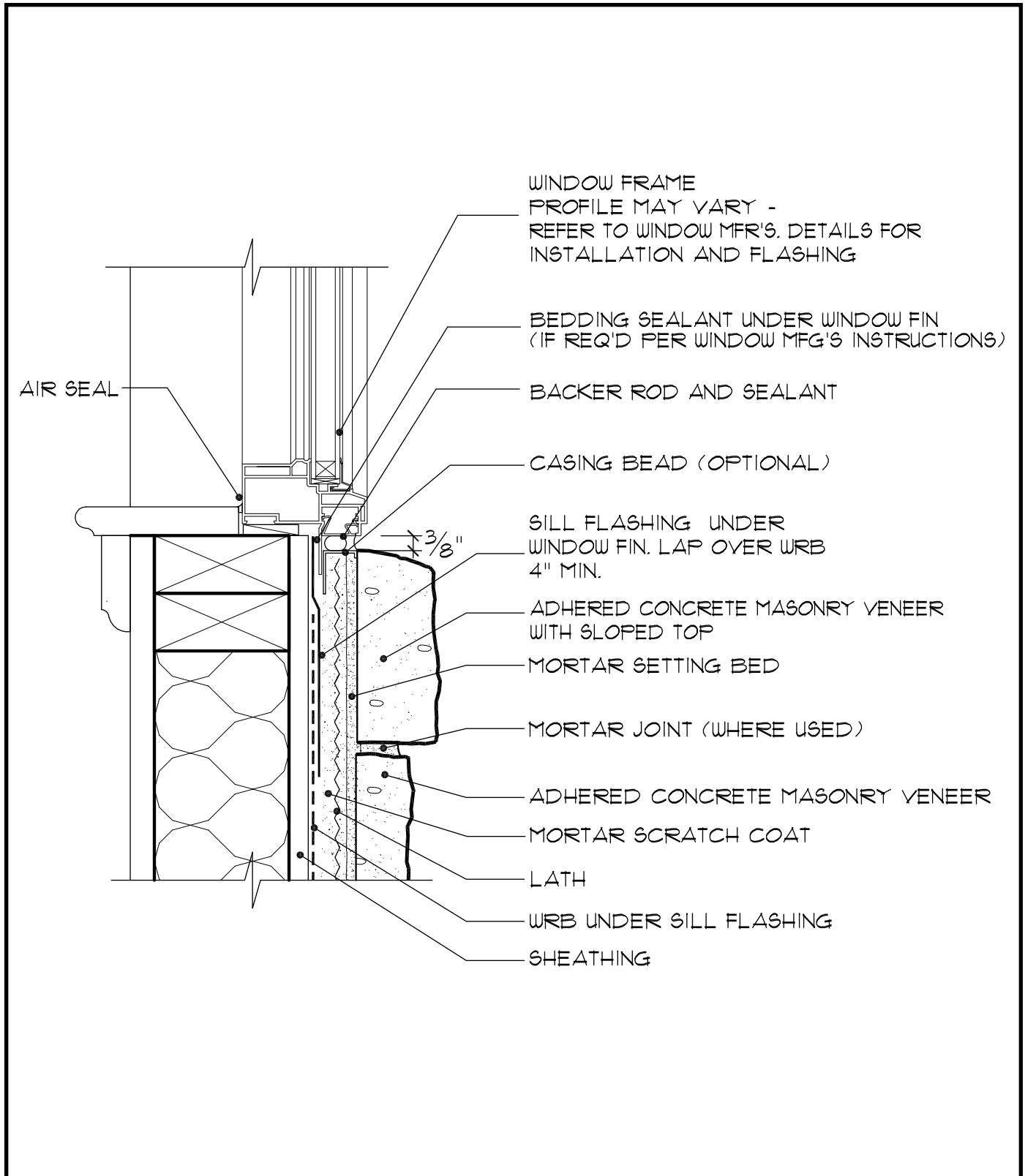

Rough openings must be properly flashed prior to window installation. Tuck water resistive barrier under flashing at sill. Sill flashing should drain to the exterior of the primary WRB or to exterior of adhered concrete masonry veneer.

Fig. 20. Window Jamb

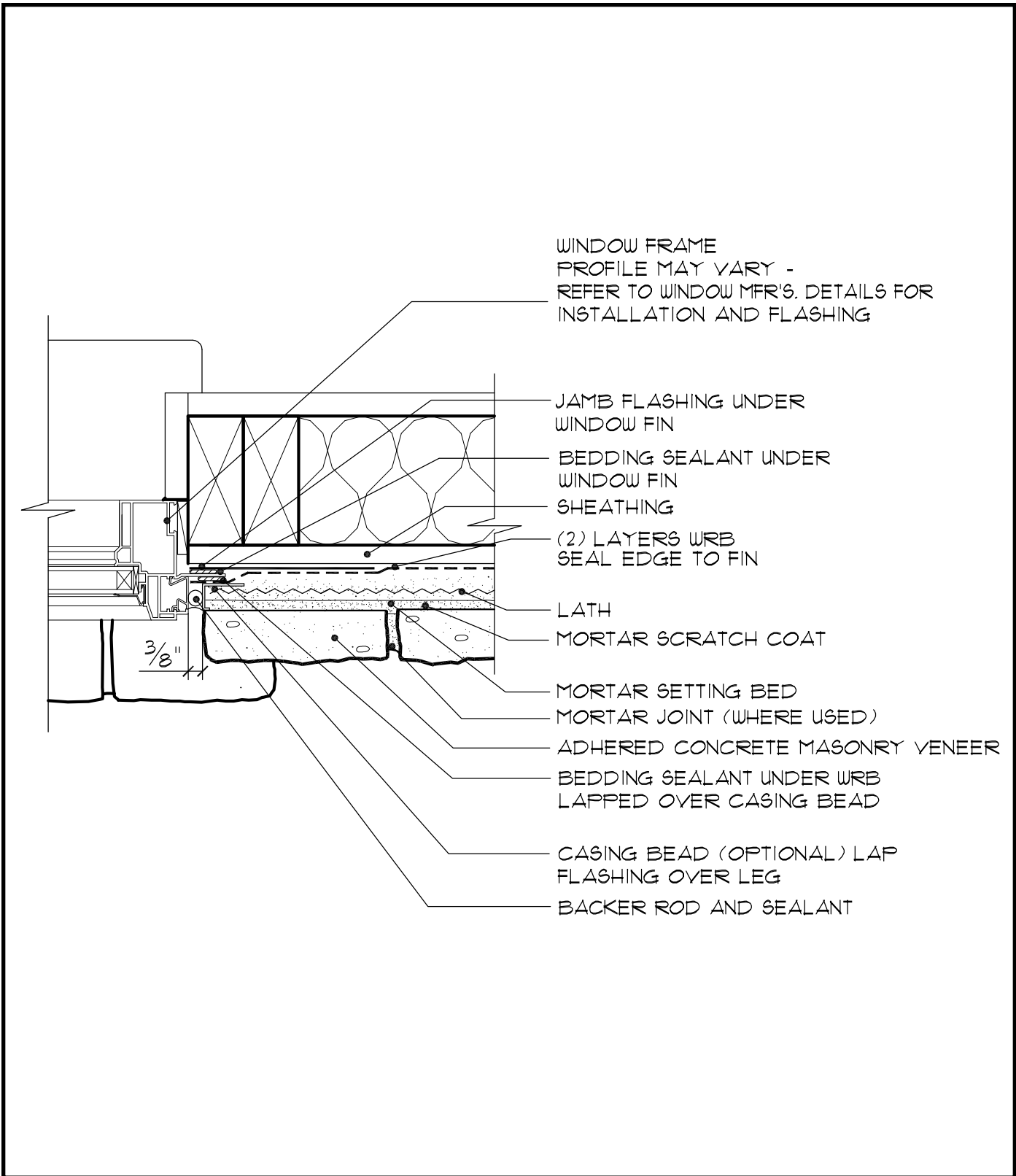

Rough openings must be properly flashed prior to window installation. Backer rod and sealant between the window frame and the adhered concrete masonry veneer allows for movement between the dissimilar materials.

Fig. 21. Window Head

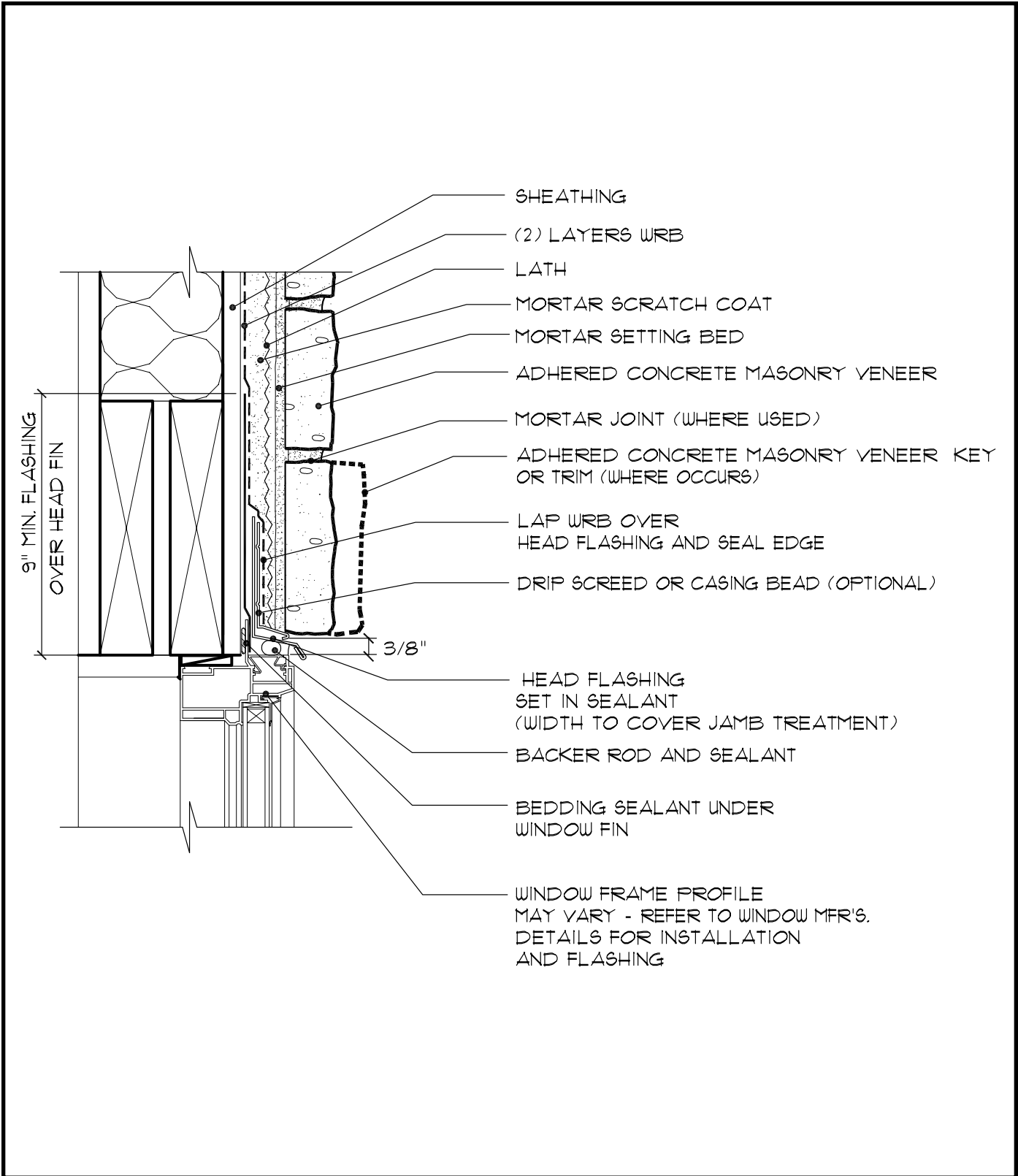

Flashing and WRB installed shingle fashion may be complimented with self-adhered flashing to seal WRB to window frame.

Fig. 22. Kick-Out Flashing

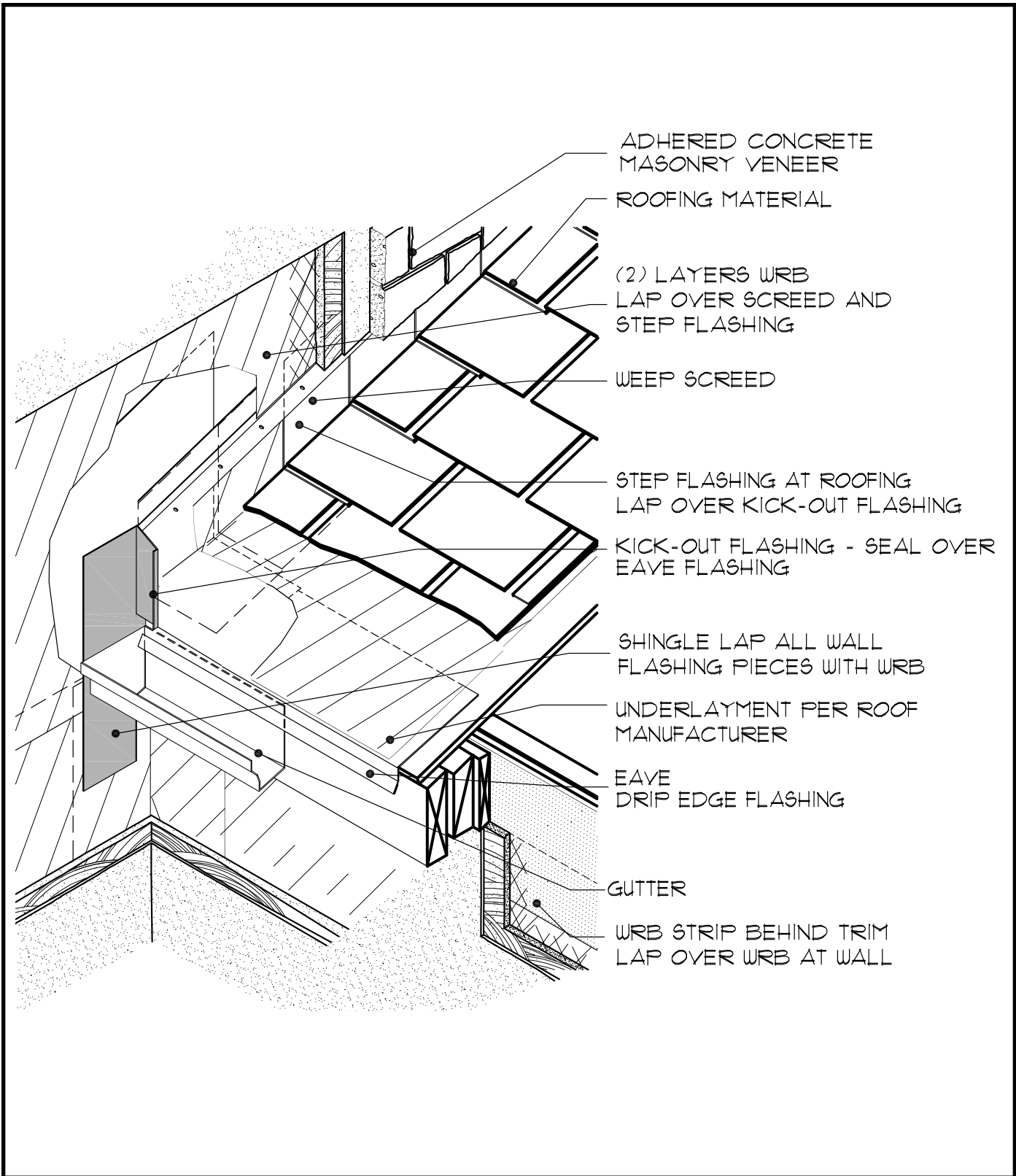

Kickout flashing should be sized properly to accommodate thickness of ACMV.

Fig. 23. Cricket

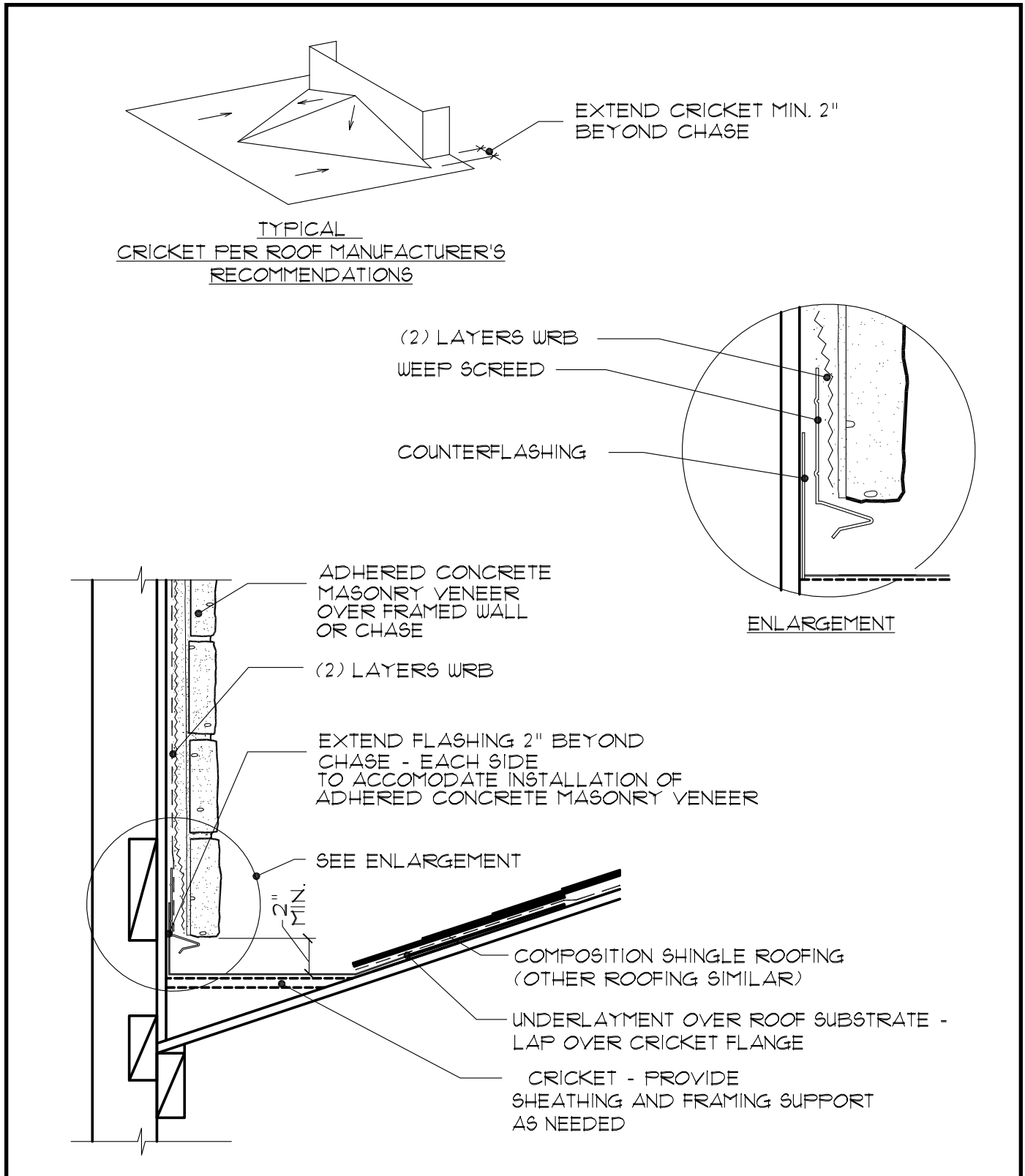

A cricket up-slope of a roof penetration, such as a chimney, helps direct water around the penetration.

Fig. 24. Chimney Chase

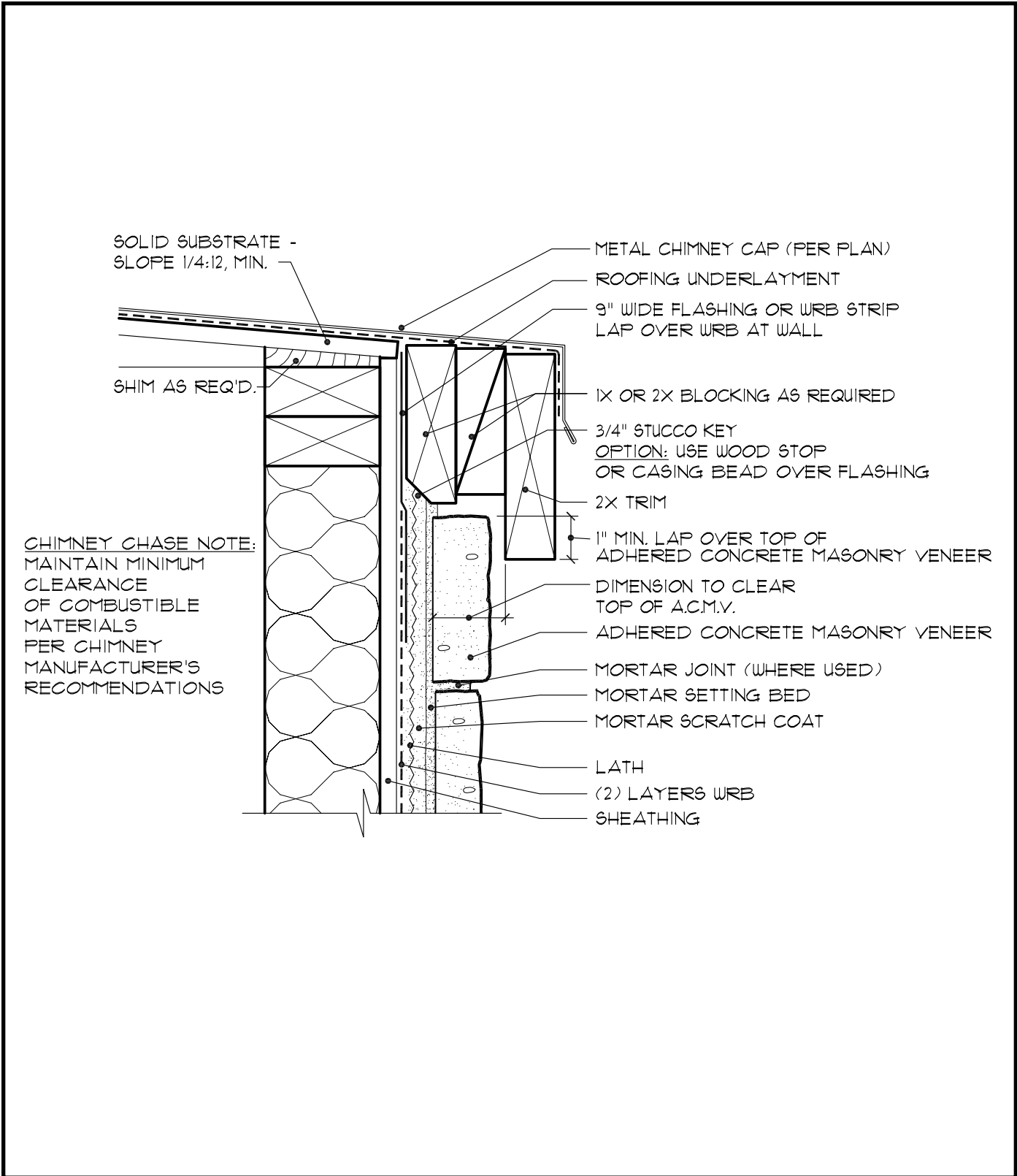
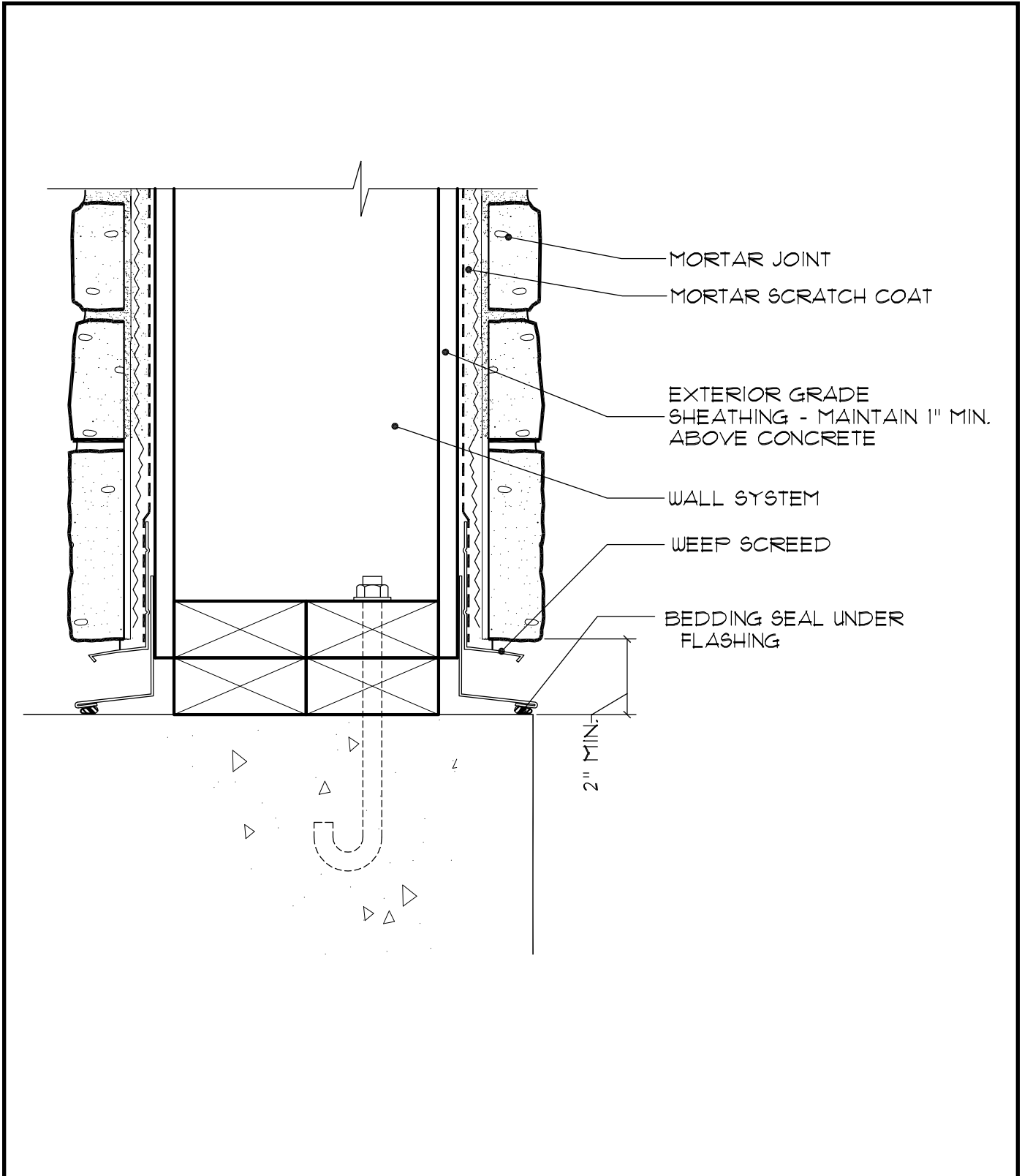
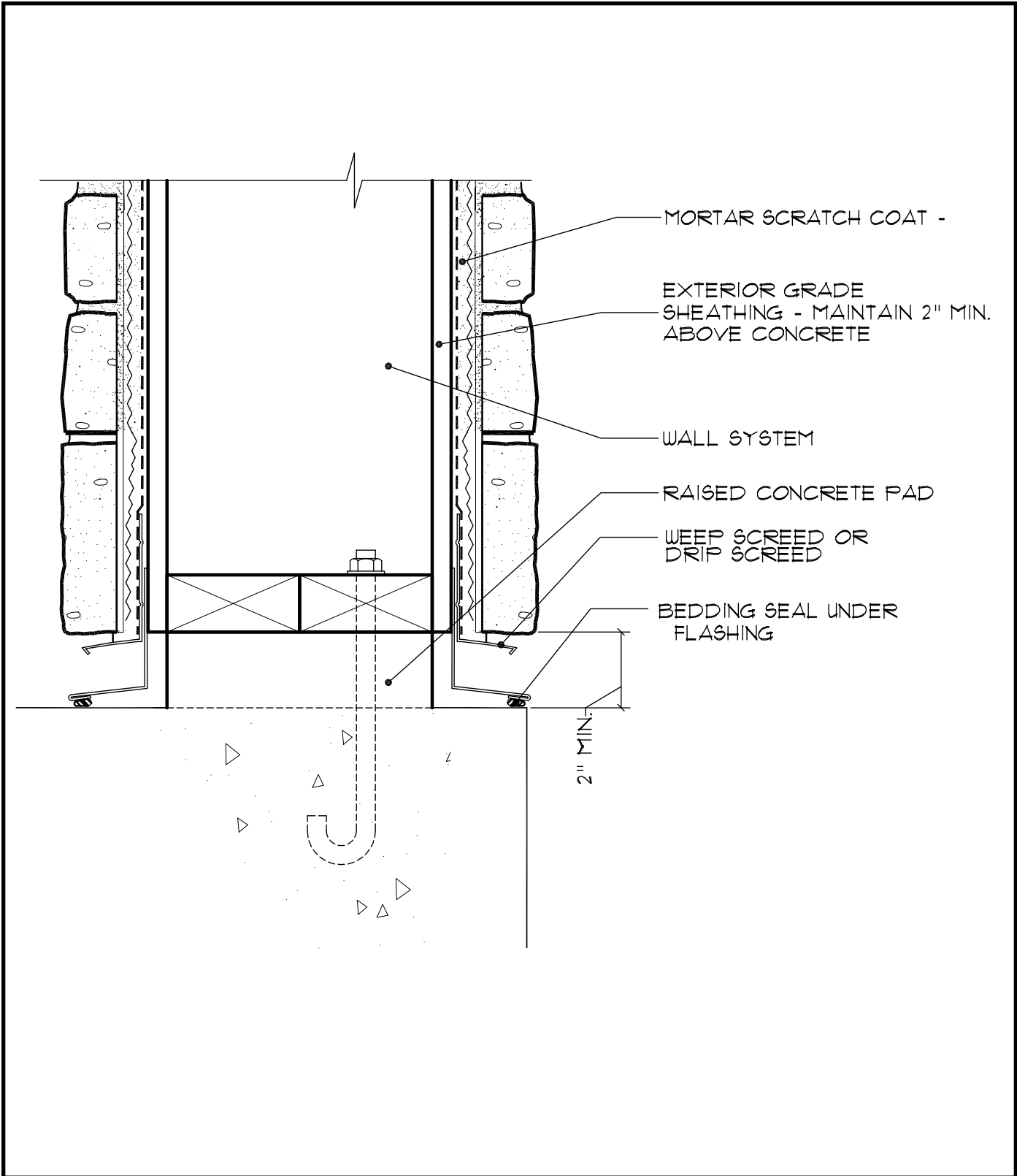

Fig. 25. Column Base



A minimum two inch clearance should be maintained at all sides of the base. All column materials to be exterior grade. Do not extend flashing past edge of ACMV for safety reasons.

Fig. 26. Raised Column Base



Adhered concrete masonry veneer may overlap the raised concrete pad, but a clearance of two inches should be maintained at all sides of the base. Do not extend flashing past edge of ACMV.

Fig. 27. Penetration, Flanged

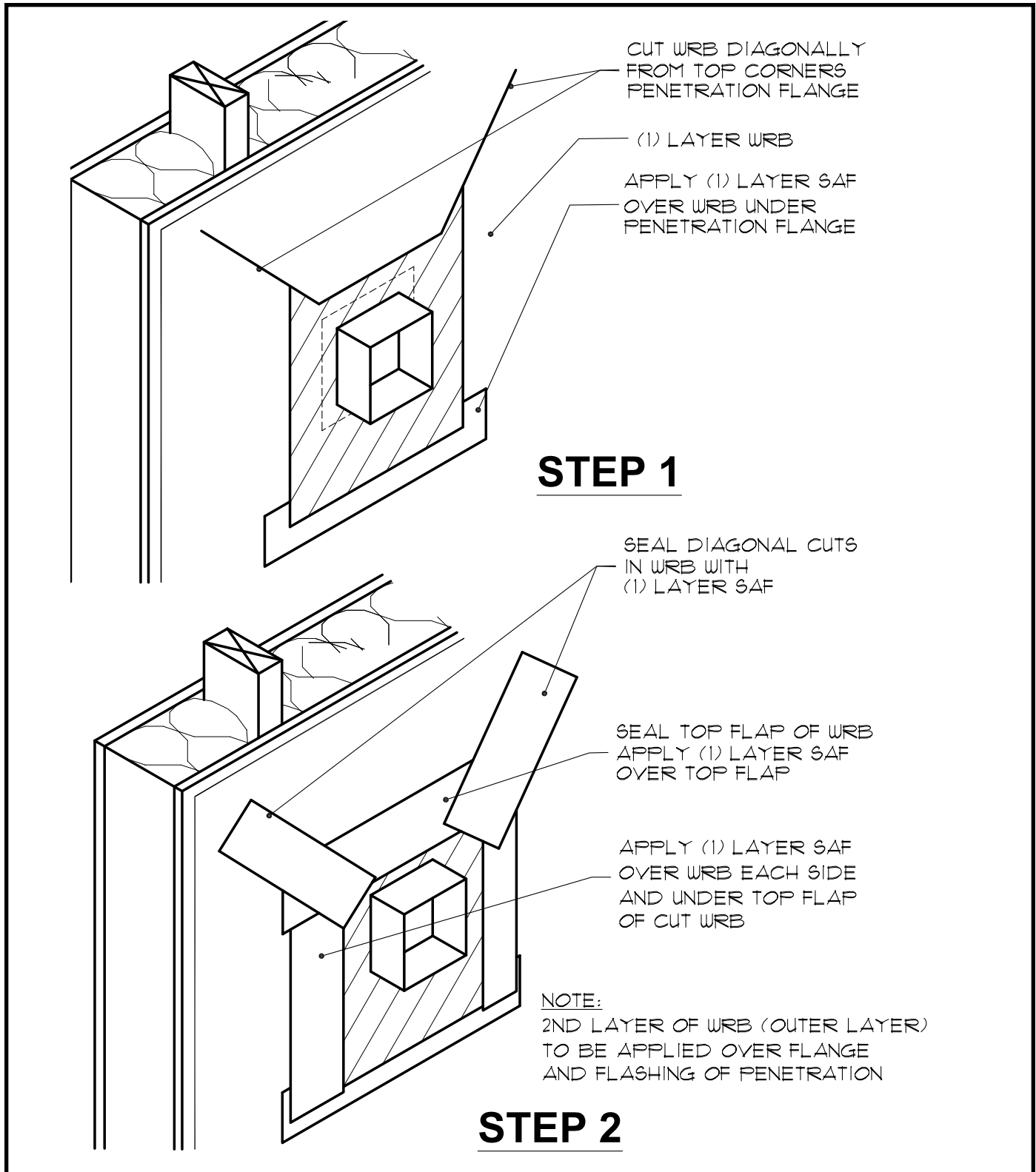

Penetration with flanges can be incorporated into the wall system by applying WRB in a watershed fashion and sealing cuts in the WRB with self-adhered flashing. Drawing illustrates installation with housewrap WRB. Installation with building paper WRB would be similar but instead of 45 degree cuts, fit last piece of WRB on top of flanges and tuck under WRB course above penetration (similar to Step 2 in Fig. 28.).

Fig. 28. Penetration Non-Flanged, with Building Paper WRB

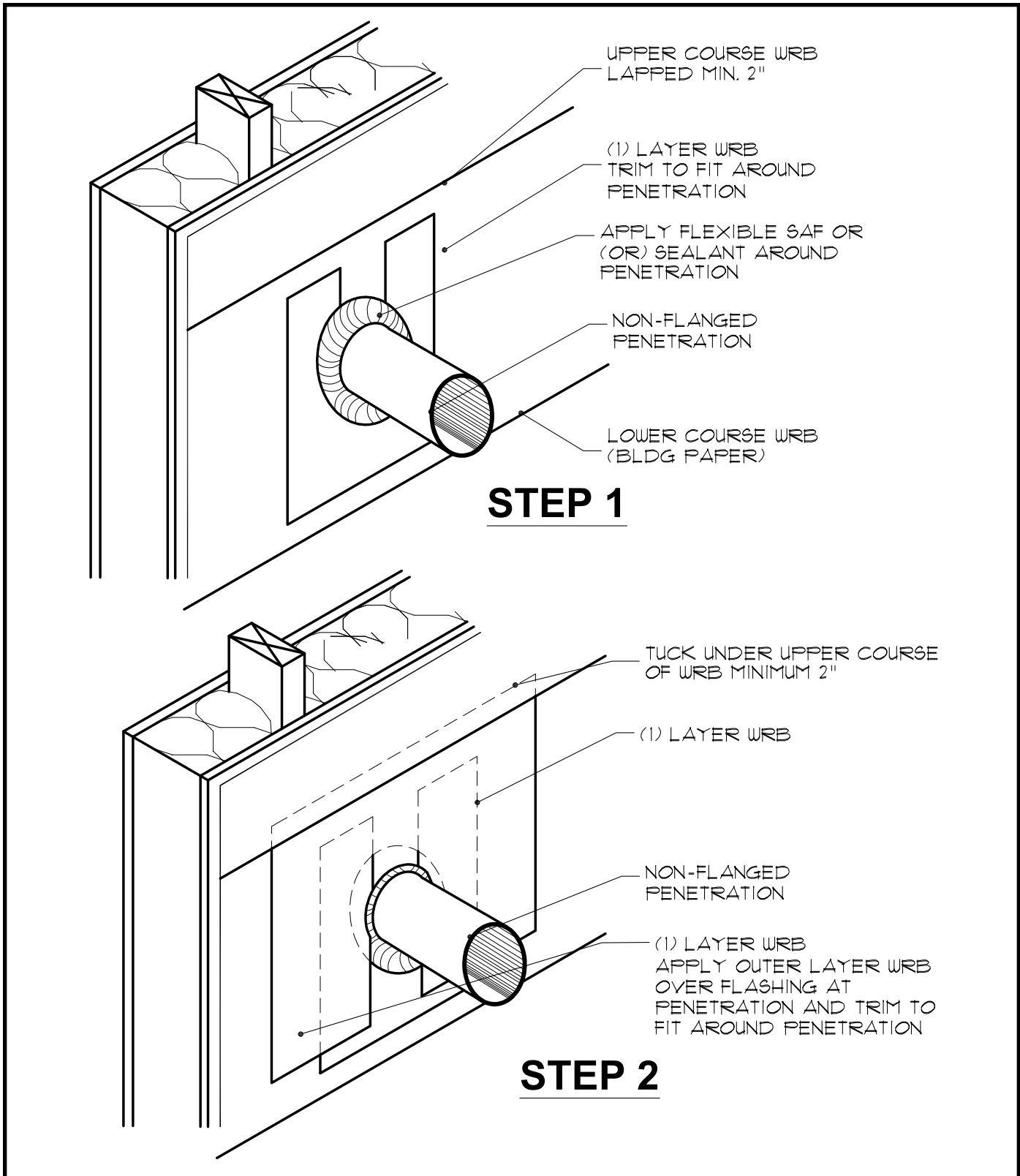

Flexible self-adhered flashing and WRB installed in a watershed fashion help prevent water infiltration.

Fig. 29. Penetration Non-Flanged, with Housewrap WRB

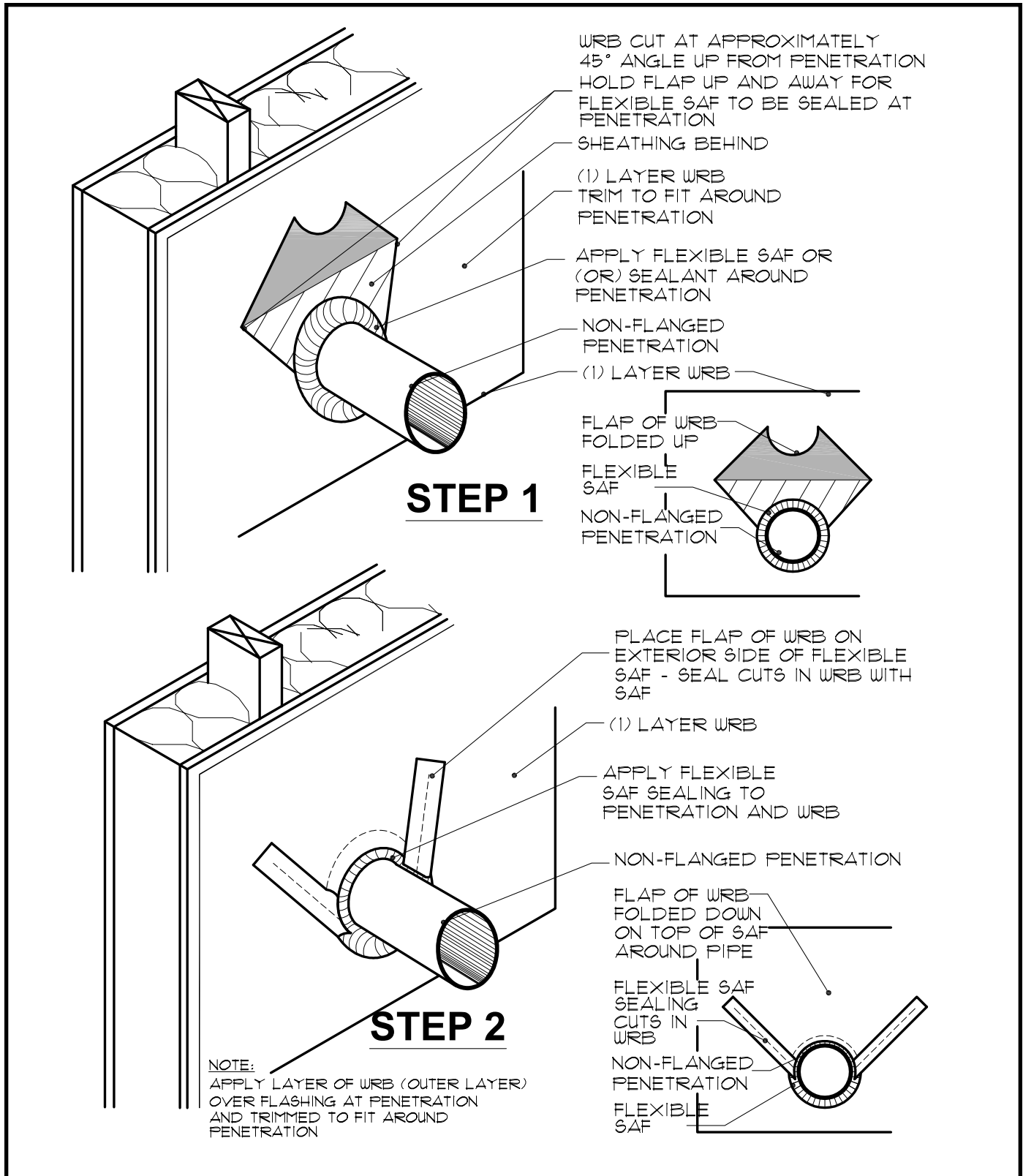

Flexible self-adhered flashing around the penetration and WRB lapped in a watershed fashion help prevent water infiltration.

Fig. 30. Penetration, Fixture

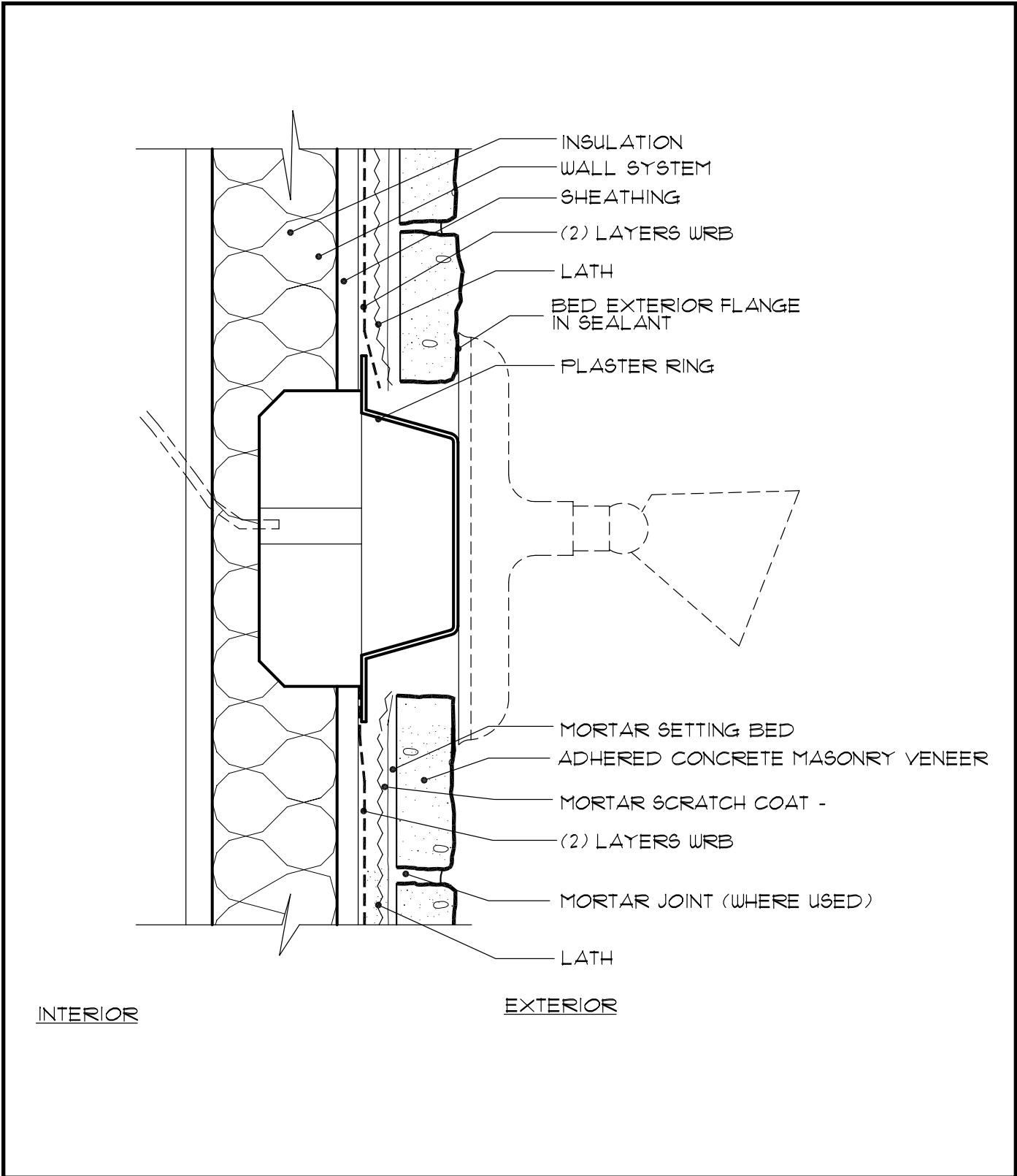

Plaster rings should be affixed over the service box to bring the face of the box flush with the adhered concrete masonry veneer. Bed the exterior flange in sealant. Water resistive barrier should be installed snugly around the plaster ring flange.

Fig. 31. Penetration, Dryer Vent

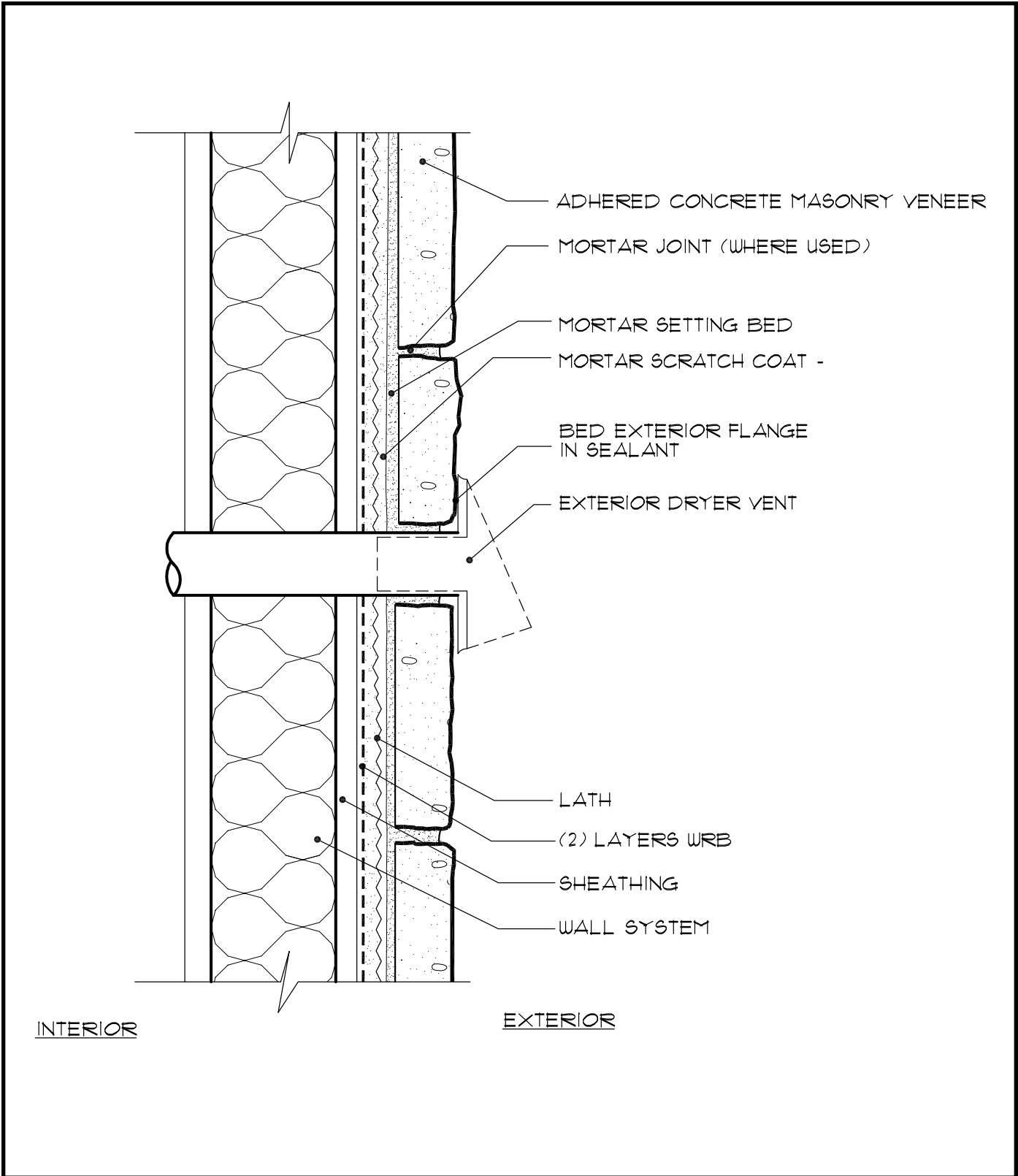

Bed all covers, flanges, and escutcheons in sealant before fastening to the wall.

Fig. 32. Deck Termination

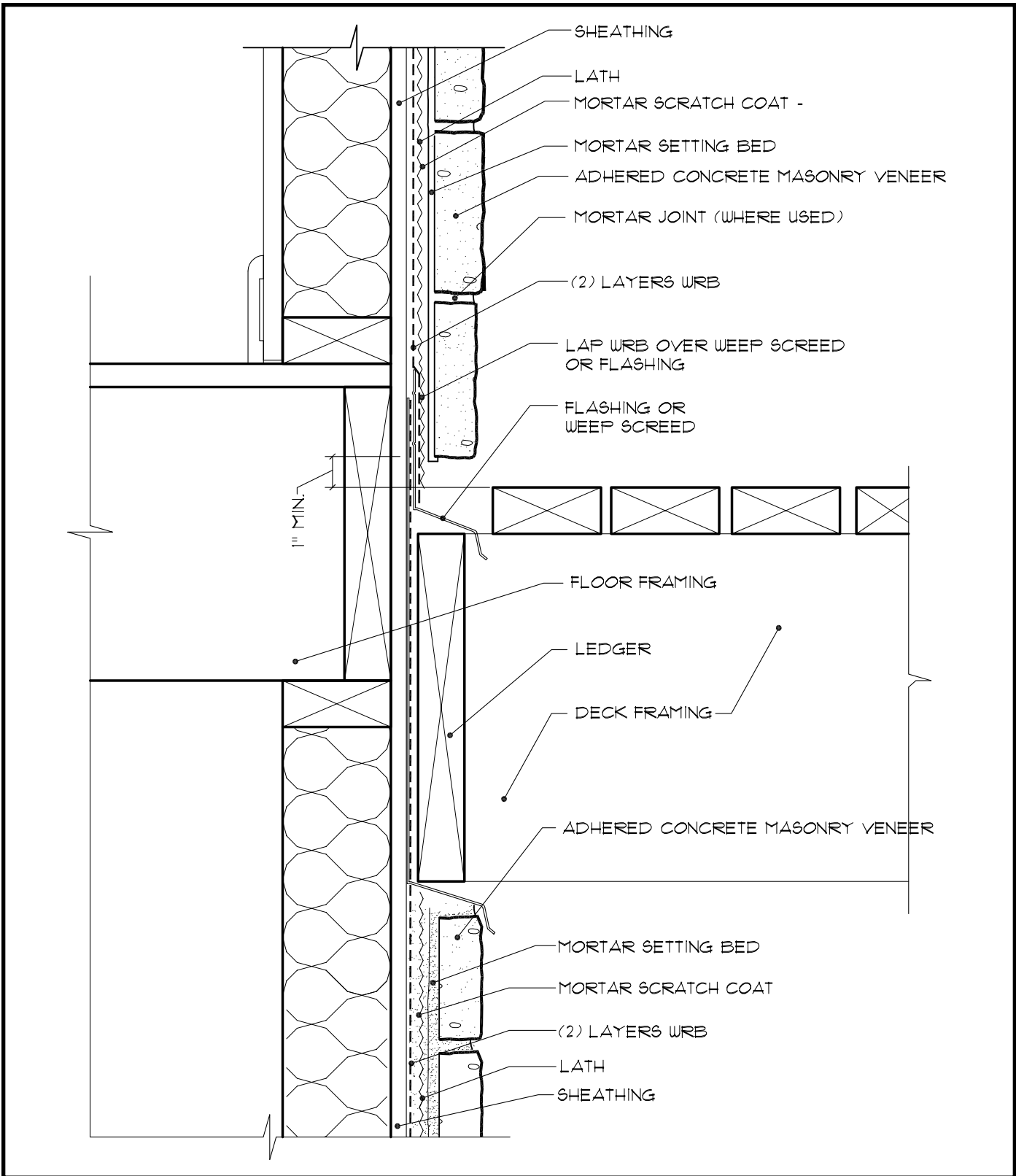

Lap water resistive barrier over weep screed and floor framing to manage water intrusion. Provide gap between adhered concrete masonry veneer and decking for drainage.

Fig. 33. Wall Cap

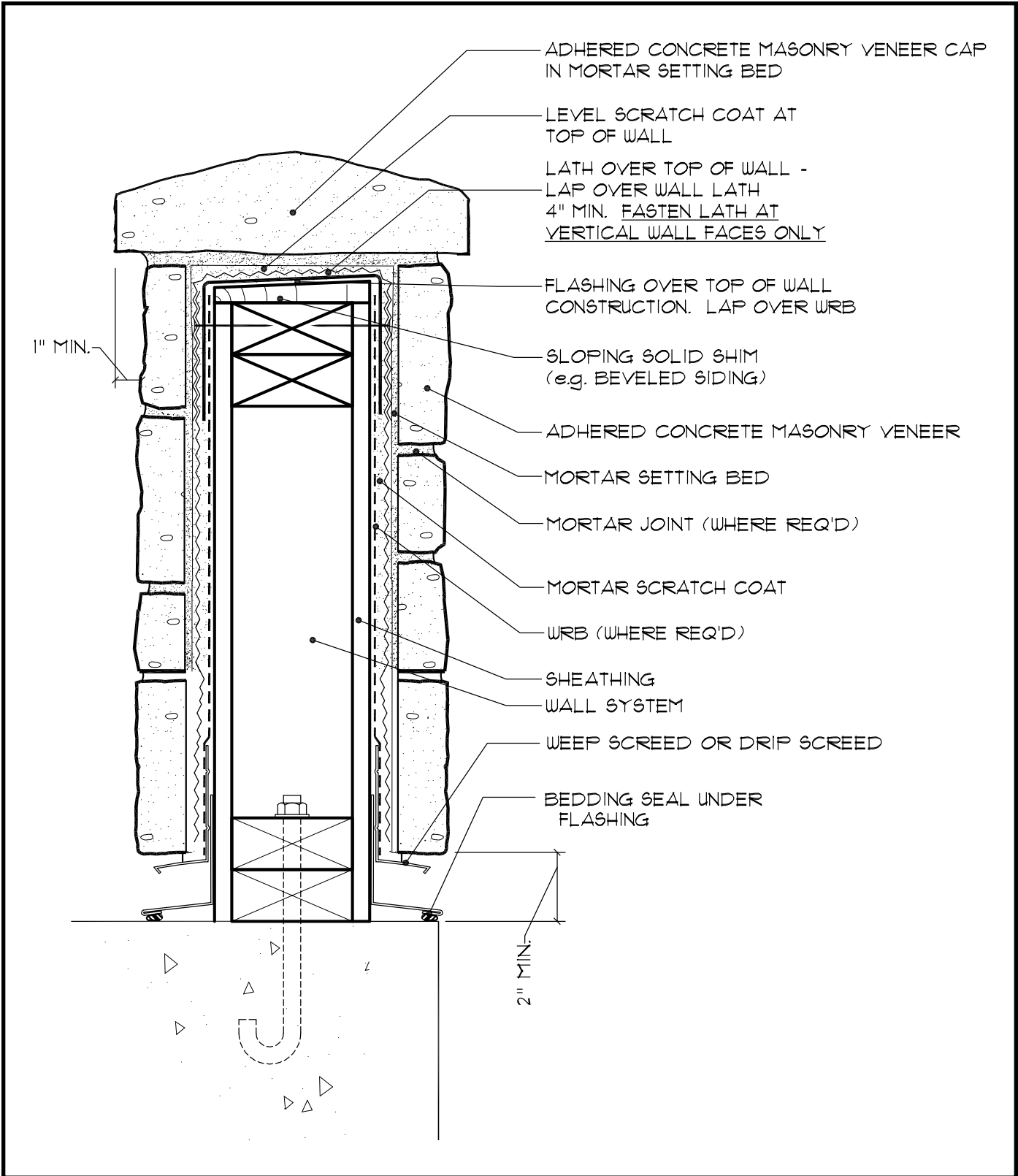

A sloping solid shim should top the wall under the flashing and lath. Flashing should lap the top of the wall. Lath should lap over the top of the wall but be fastened only to vertical wall faces.

Fig. 34. Wall Assembly - Optional Rainscreen System - Drainage System

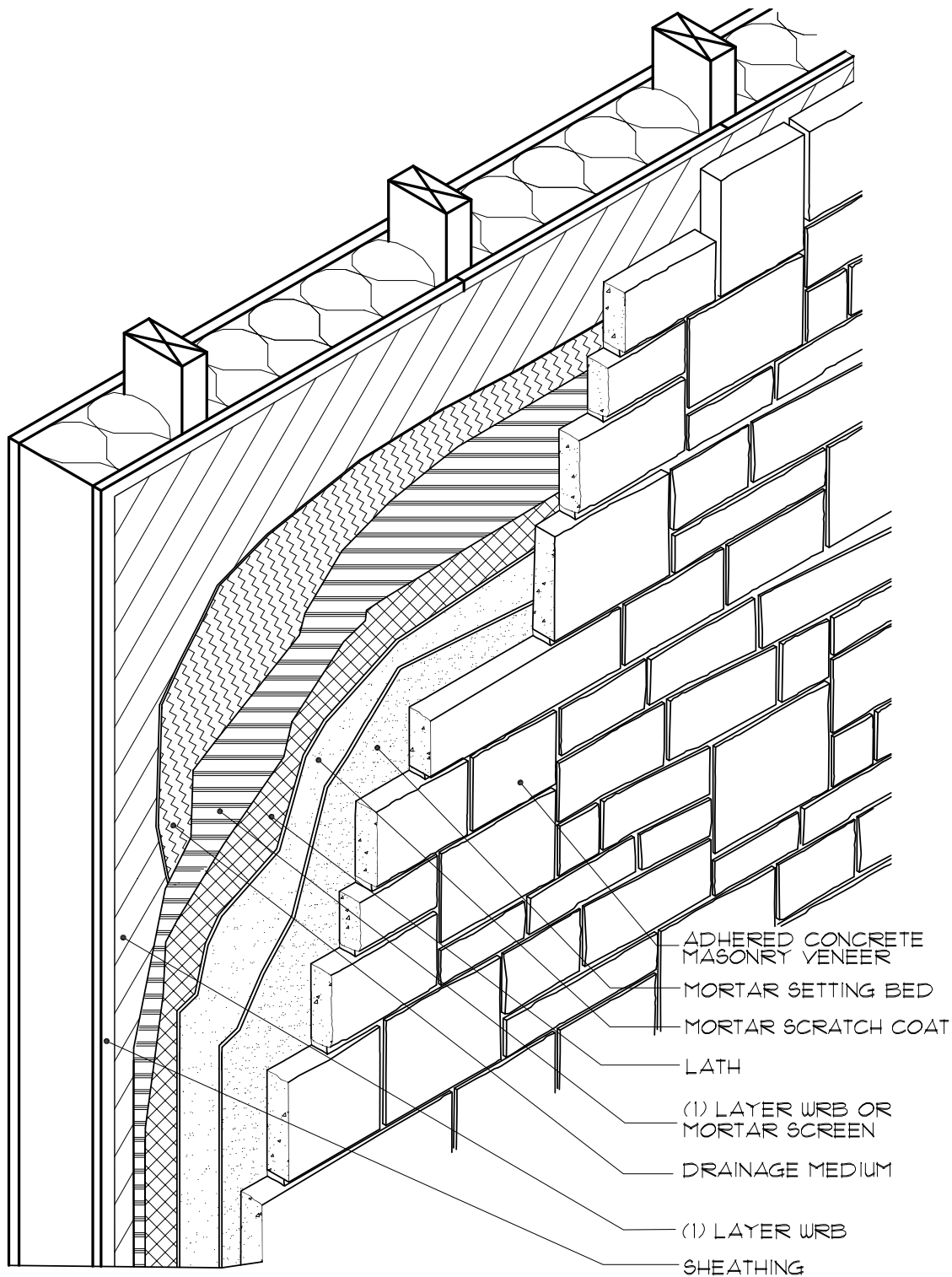

A rainscreen system incorporating a drainage medium (drainage mat or formed polymer sheeting, etc.) on the exterior side of the primary WRB.

Fig. 35. Wall Assembly - Optional Rainscreen System - Strapped

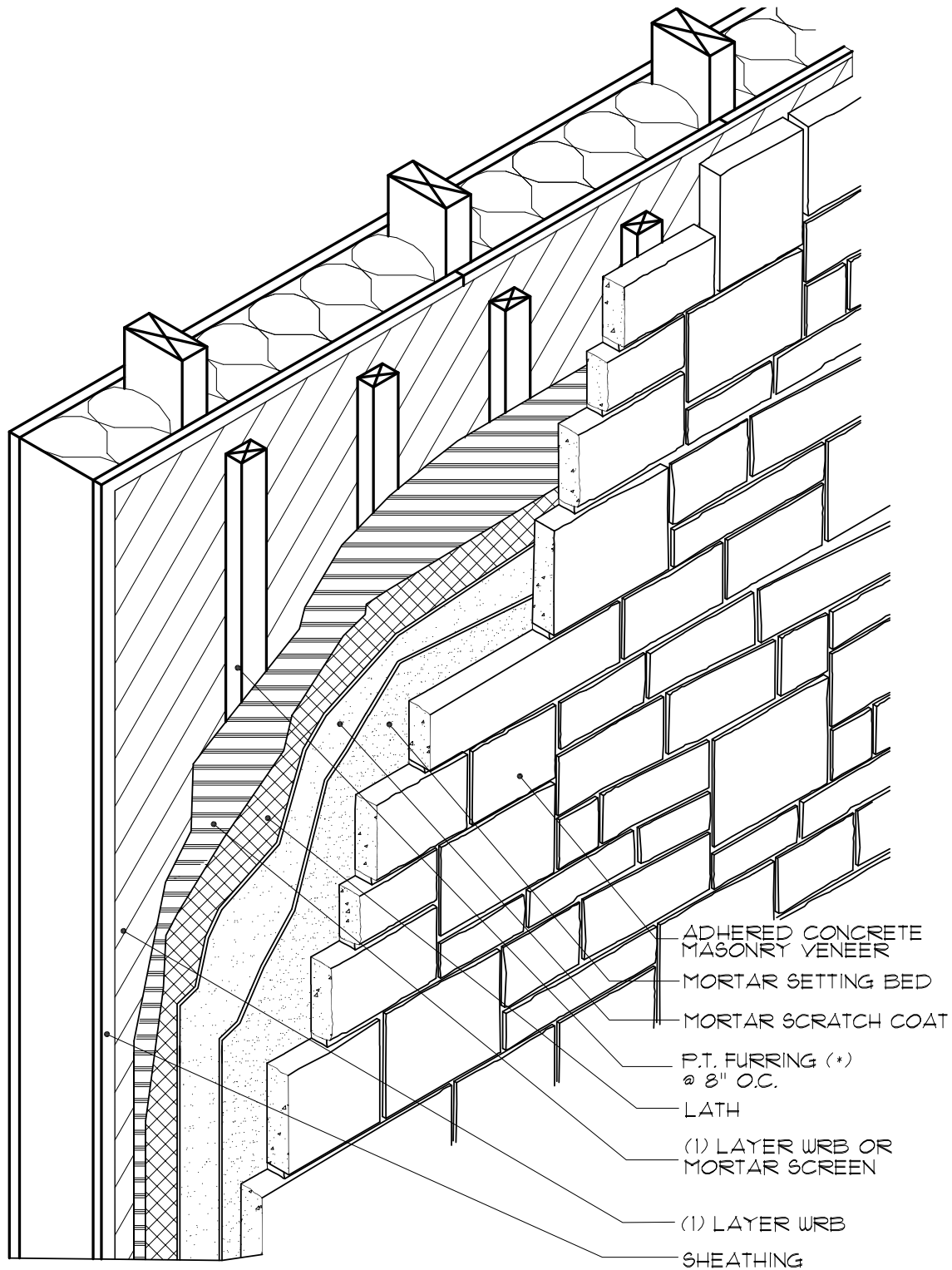

A rainscreen system of vertical strapping / furring creates a vertical gap between the primary WRB and the mortar screen / WRB on the back of the scratch coat. *Furring fastened into framing and into nailable sheathing between framing.

Fig. 36. Foundation Wall Base - Optional Rainscreen System

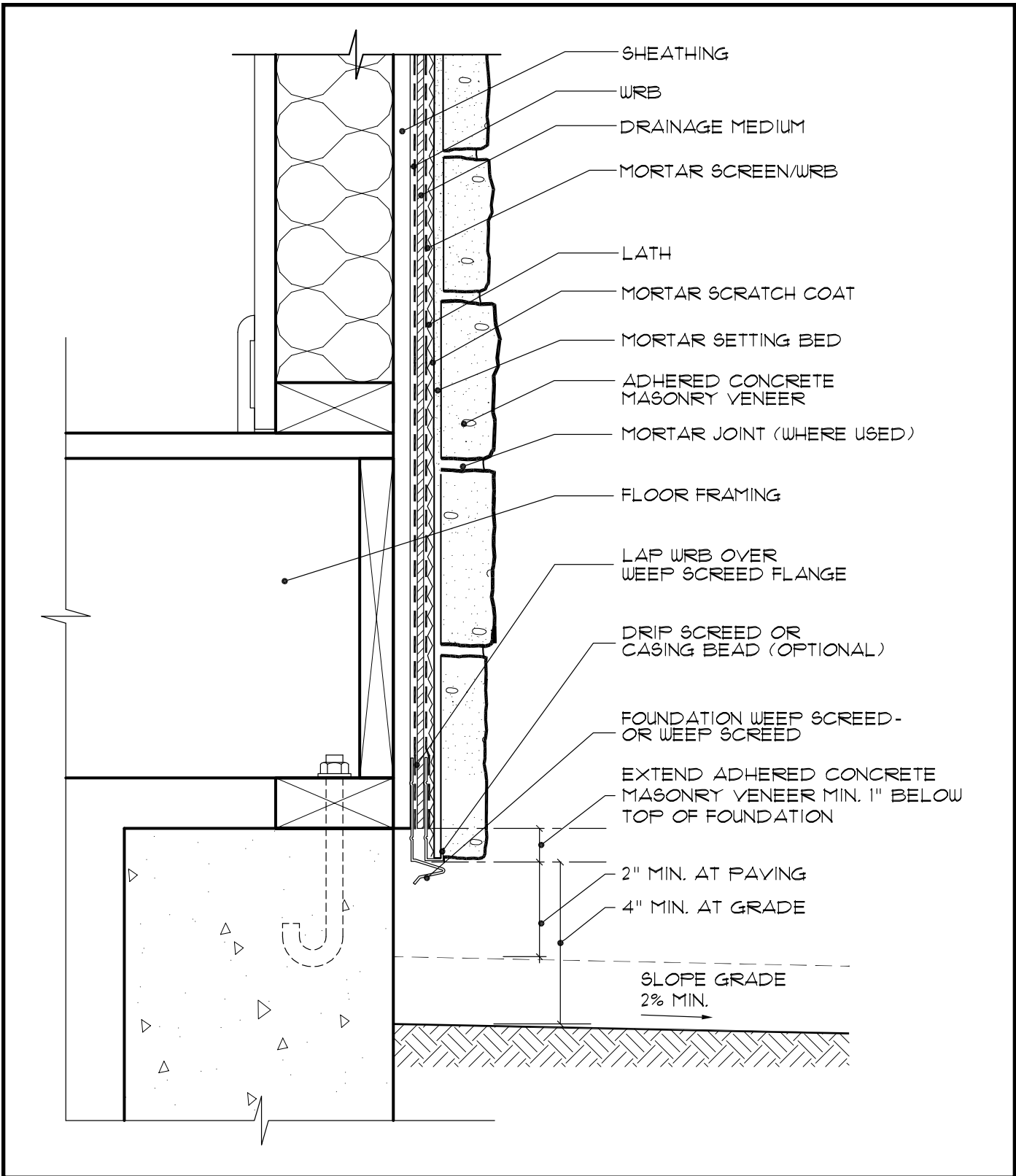

The “Drainage Medium” of this wall section represents rainscreen products (such as drainage mats or formed polymer sheeting, etc.) or construction techniques (such as strapping or furring).

Fig. 37. Typical Wall Section - Optional Rainscreen System

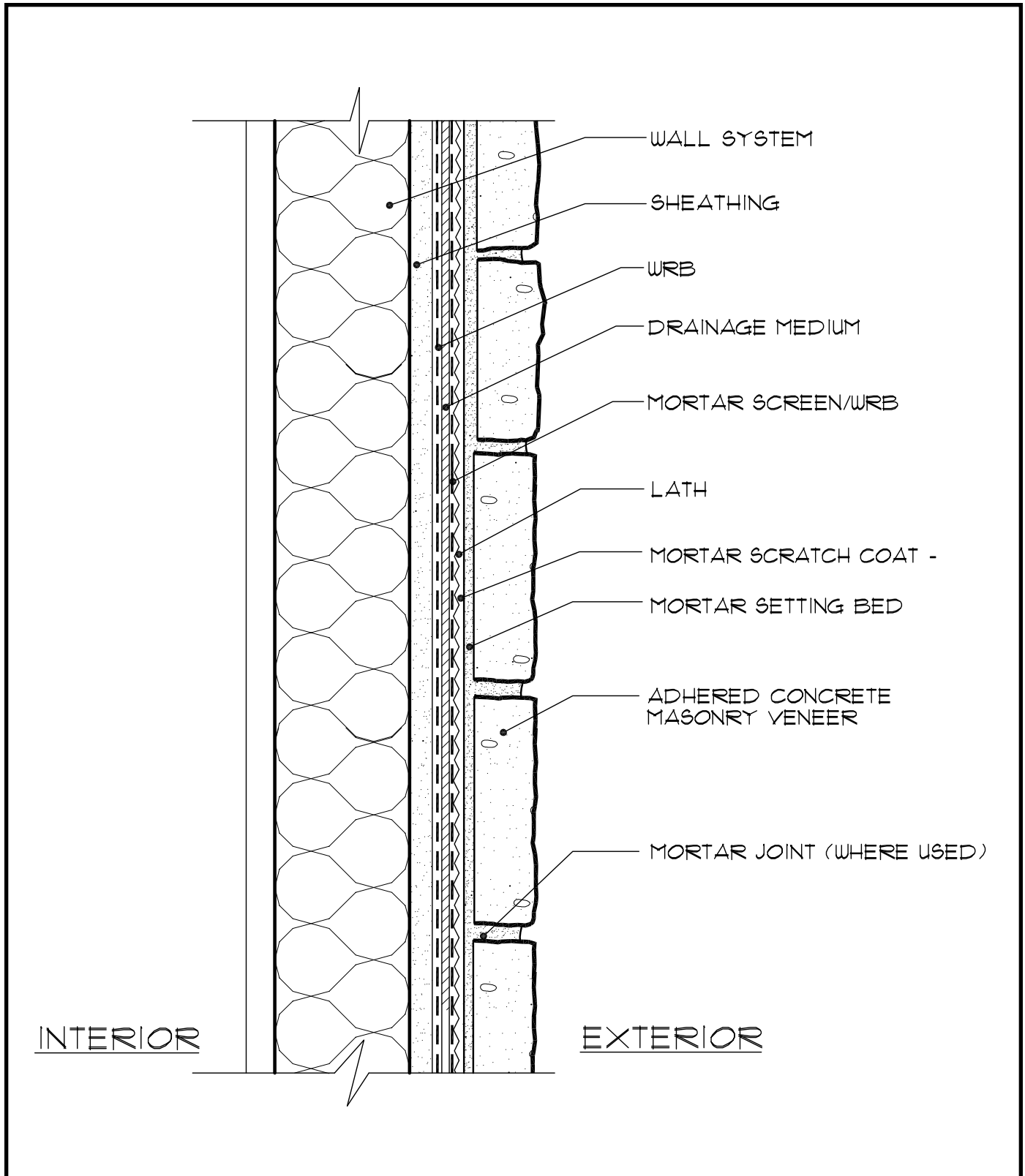

The “Drainage Medium” of this wall section represents rainscreen products (such as drainage mats or formed polymer sheeting, etc.) or construction techniques (such as strapping or furring).

Fig. 38. Retaining Wall (CMU)

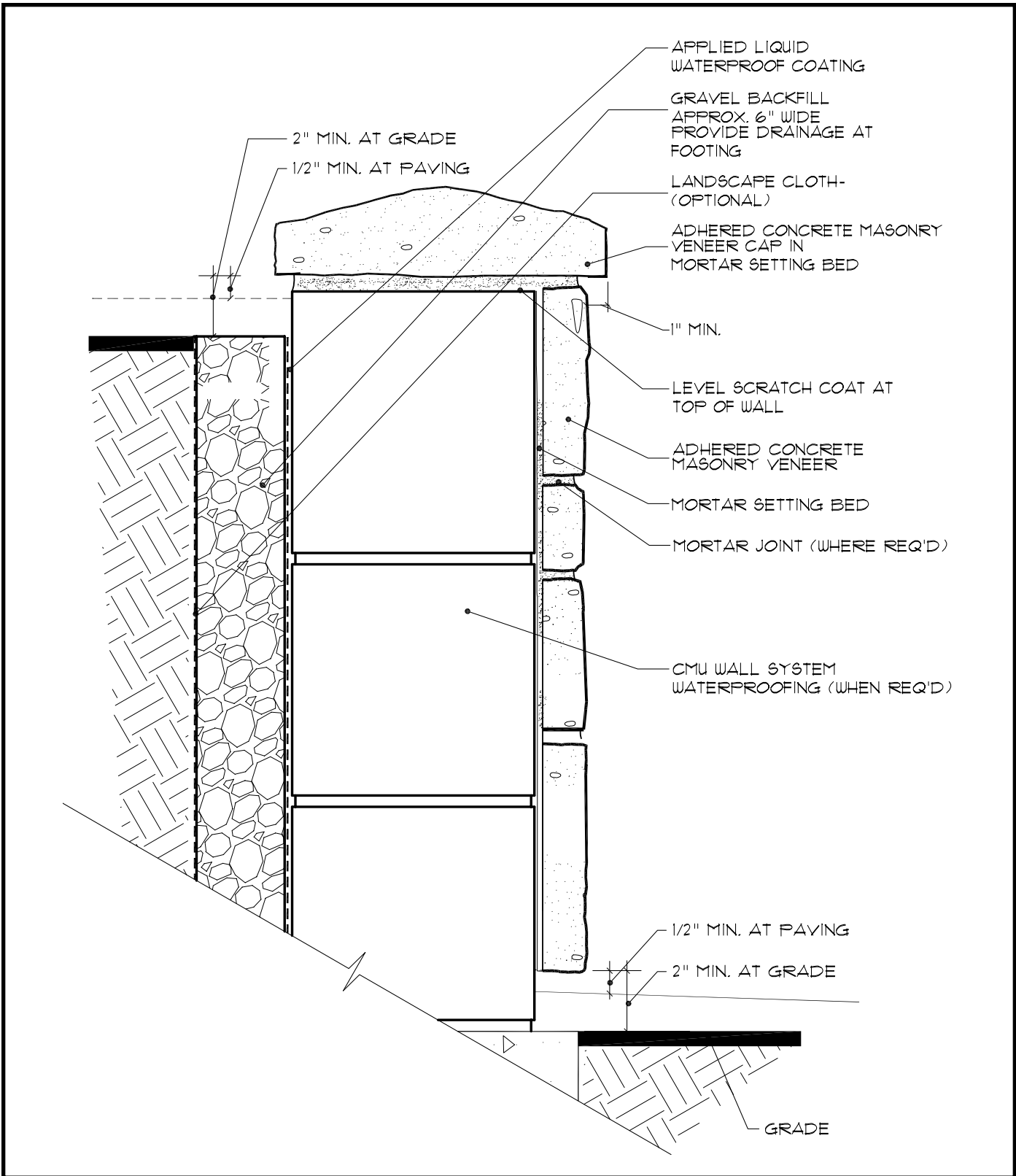

Adhered masonry veneer offers attractive aesthetics to retaining walls.

Notes:

